

## CE EMC Test Report (EN 50155 & EN 50121-3-2)

**Report No.:** CE190401D10

**Test Model:** SPC-4020A

**Series Model:** SPC-4XXXXXXXXXXXXXXXXX ("X" can be 0-9, A-Z or blank for marketing purpose)

**Received Date:** Apr. 1, 2019

**Test Date:** Apr. 10 to 26, 2019

**Issued Date:** May 8, 2019

**Applicant:** Vecow Co., Ltd.

**Address:** 3F., No.10, Jiankang Rd., Zhonghe Dist., New Taipei City 23586, Taiwan

**Issued By:** Bureau Veritas Consumer Products Services (H.K.) Ltd., Taoyuan Branch

**Lab Address:** No. 47-2, 14th Ling, Chia Pau Vil., Lin Kou Dist., New Taipei City, Taiwan (R.O.C.)

**Test Location (1):** No. 47-2, 14th Ling, Chia Pau Vil., Lin Kou Dist., New Taipei City, Taiwan (R.O.C.)

**Test Location (2):** No. 49, Ln. 206, Wende Rd., Shangshan Tsuen, Chiung Lin Hsiang, Hsin Chu Hsien 307, Taiwan R.O.C.



This report is for your exclusive use. Any copying or replication of this report to or for any other person or entity, or use of our name or trademark, is permitted only with our prior written permission. This report sets forth our findings solely with respect to the test samples identified herein. The results set forth in this report are not indicative or representative of the quality or characteristics of the lot from which a test sample was taken or any similar or identical product specifically and expressly noted. Our report includes all of the tests requested by you and the results thereof based upon the information that you provided to us. You have 60 days from date of issuance of this report to notify us of any material error or omission caused by our negligence, provided, however, that notice shall be in writing and shall specifically address the issue you wish to raise. A failure to raise such issue within the prescribed time shall constitute your unqualified acceptance of the completeness of this report, the tests conducted and the correctness of the report contents. Unless specific mention, the uncertainty of measurement has been explicitly taken into account to declare the compliance or non-compliance to the specification. The report must not be used by the client to claim product certification, approval, or endorsement by TAF or any government agencies.

## Table of Contents

<b>Release Control Record</b> .....	<b>4</b>
<b>1 Certificate of Conformity</b> .....	<b>5</b>
<b>2 Summary of Test Results</b> .....	<b>6</b>
2.1 Performance Criteria .....	8
2.2 Measurement Uncertainty .....	8
2.3 Modification Record.....	8
<b>3 General Information</b> .....	<b>9</b>
3.1 Description of EUT .....	9
3.2 Features of EUT .....	9
3.3 Operating Modes of EUT and Determination of Worst Case Operating Mode .....	10
3.4 Test Program Used and Operation Descriptions.....	11
3.5 Primary Clock Frequencies of Internal Source .....	11
<b>4 Configuration and Connections with EUT</b> .....	<b>12</b>
4.1 Connection Diagram of EUT and Peripheral Devices.....	12
4.2 Configuration of Peripheral Devices and Cable Connections .....	14
<b>5 Conducted Disturbance at Auxiliary a.c. or d.c. Power Ports</b> .....	<b>16</b>
5.1 Limits .....	16
5.2 Test Instruments .....	16
5.3 Test Arrangement .....	17
5.4 Test Results .....	18
<b>6 Radiated Disturbance up to 1 GHz</b> .....	<b>20</b>
6.1 Limits .....	20
6.2 Test Instruments .....	20
6.3 Test Arrangement .....	21
6.4 Test Results .....	22
<b>7 Radiated Disturbance above 1 GHz</b> .....	<b>24</b>
7.1 Limits .....	24
7.2 Test Instruments .....	25
7.3 Test Arrangement .....	26
7.4 Test Results .....	27
<b>8 Electrostatic Discharge Immunity Test (ESD)</b> .....	<b>29</b>
8.1 Test Specification.....	29
8.2 Test Instruments .....	29
8.3 Test Arrangement .....	30
8.4 Test Results .....	31
<b>9 Radio-frequency Electromagnetic Field Immunity Test (RS)</b> .....	<b>35</b>
9.1 Test Specification.....	35
9.2 Test Instruments .....	35
9.3 Test Arrangement .....	36
9.4 Test Results .....	37
<b>10 Electrical Fast Transient/Burst Immunity Test (EFT)</b> .....	<b>38</b>
10.1 Test Specification.....	38
10.2 Test Instruments .....	38
10.3 Test Arrangement .....	39
10.4 Test Results .....	40

<b>11</b>	<b>Surge Immunity Test.....</b>	<b>41</b>
11.1	Test Specification.....	41
11.2	Test Instruments .....	41
11.3	Test Arrangement .....	42
11.4	Test Results .....	42
<b>12</b>	<b>Immunity to Conducted Disturbances Induced by RF Fields (CS).....</b>	<b>43</b>
12.1	Test Specification.....	43
12.2	Test Instruments .....	43
12.3	Test Arrangement .....	44
12.4	Test Results .....	45
<b>13</b>	<b>Pictures of Test Arrangements .....</b>	<b>46</b>
13.1	Conducted Disturbance at Auxiliary a.c. or d.c. power ports .....	46
13.2	Radiated Disturbance up to 1 GHz .....	47
13.3	Radiated Disturbance above 1 GHz.....	48
13.4	Electrostatic Discharge Immunity Test (ESD) .....	49
13.5	Radio-frequency Electromagnetic Field Immunity Test (RS) .....	50
13.6	Fast Transients (EFT).....	51
13.7	Surge .....	53
13.8	Radio-frequency common mode (CS).....	54
<b>Appendix – Information of the Testing Laboratories .....</b>		<b>55</b>

### Release Control Record

Issue No.	Description	Date Issued
CE190401D10	Original release.	May 8, 2019



## 2 Summary of Test Results

EN 50121-3-2:2016, Emission requirements, EN 50155:2017, Clause 13.4.8			
Port	Test Item / specifications	Result/Remarks	Verdict
Auxiliary a.c. or d.c. power ports - Auxiliary supply sinusoidal a.c. or d.c.	Conducted disturbance 150 kHz- 500 kHz: 99 dB $\mu$ V quasi-peak 500 kHz- 30 MHz: 93 dB $\mu$ V quasi-peak	Minimum passing margin is -47.15 dB at 13.99300 MHz	Pass
Auxiliary a.c. or d.c. power ports – AC power outlet port for public use	Conducted disturbance 50 Hz- 2 kHz: THD <8% (THD: total harmonic distortion)	Test not applicable because the port does not exist.	N/A
Battery referenced ports - Battery power supply	Conducted disturbance 150 kHz- 500 kHz: 99 dB $\mu$ V quasi-peak 500 kHz- 30 MHz: 93 dB $\mu$ V quasi-peak	Test not applicable because the port does not exist.	N/A
Enclosure	Radiated disturbance 30 MHz- 230 MHz: 40 dB $\mu$ V/m quasi-peak 230 MHz -1 GHz: 47 dB $\mu$ V/m quasi-peak	Minimum passing margin is -2.06 dB at 224.34 & 295.64 MHz	Pass
Enclosure	Radiated disturbance 1 GHz- 3 GHz: 76 dB $\mu$ V/m peak 56 dB $\mu$ V/m average 3 GHz - 6 GHz: 80 dB $\mu$ V/m peak 60 dB $\mu$ V/m average	Minimum passing margin is -12.32 dB at 1780.07 MHz	Pass

EN 50121-3-2:2016, Immunity requirements, EN 50155:2017, Clause 13.4.8					
Table Clause	Basic standard	Port	Test Item / specifications	Result/Remarks	Verdict
3.1	EN 61000-4-6:2014 +AC:2015	Battery referenced ports (except at the output of energy sources), Auxiliary a.c. power input ports (rated voltage $\leq$ 400 Vrms)	Radio-frequency common mode (CS) 80% AM (1kHz) 0.15-80 MHz, 10V Performance Criterion A	Performance Criterion A	Pass
3.2	EN 61000-4-4:2012	Battery referenced ports (except at the output of energy sources), Auxiliary a.c. power input ports (rated voltage $\leq$ 400 Vrms)	Fast Transients (EFT) 5/50 ( $T_r/T_h$ ) ns, 5kHz $\pm$ 2kV Performance Criterion A	Performance Criterion A	Pass
3.3	EN 61000-4-5:2014 +A1:2017	Battery referenced ports (except at the output of energy sources), Auxiliary a.c. power input ports (rated voltage $\leq$ 400 Vrms)	Surges 1.2/50 (8/20) ( $T_r/T_h$ ) $\mu$ s Line to ground: $\pm$ 2kV 42 $\Omega$ , 0.5 $\mu$ F Line to line: $\pm$ 1kV 42 $\Omega$ , 0.5 $\mu$ F Performance Criterion B	Performance Criterion A	Pass

EN 50121-3-2:2016, Immunity requirements, EN 50155:2017, Clause 13.4.8					
Table Clause	Basic standard	Port	Test Item / specifications	Result/Remarks	Verdict
4.1	EN 61000-4-6:2014 +AC:2015	Signal & communication, process measurement & control ports	Radio-frequency common mode (CS) 80% AM (1kHz) 0.15-80 MHz, 10V Performance Criterion A	Performance Criterion A	Pass
4.2	EN 61000-4-4:2012	Signal & communication, process measurement & control ports	Fast Transients (EFT) 5/50 (T <sub>r</sub> /T <sub>h</sub> ) ns, 5kHz ±2kV, Capacitive clamp Performance Criterion A	Performance Criterion A	Pass
5.1	EN 61000-4-3:2006 +A1:2008 +A2:2010	Enclosure ports	Radio-frequency electromagnetic field amplitude modulated (RS) <sup>1</sup> , 80% AM (1kHz) 80-800 MHz, 20V/m Performance Criterion A	Performance Criterion A	Pass
5.2	EN 61000-4-3:2006 +A1:2008 +A2:2010	Enclosure ports	Radio-frequency electromagnetic field from digital mobile telephones (RS) <sup>2</sup> , 80% AM (1kHz) 800-1000 MHz, 20V/m 1400-2000 MHz, 10V/m 2000-2700 MHz, 5V/m 5100-6000 MHz, 3V/m Performance Criterion A	Performance Criterion A	Pass
5.3	EN 61000-4-2:2009	Enclosure ports	Electrostatic Discharges (ESD) ±6kV Contact discharge ±8kV Air discharge Performance Criterion B	Performance Criterion B	Pass

Note 1: This limit applies to equipment mounted in the passenger compartments, drivers cab or external to the rolling stock (roof, underframe). For equipment mounted in all other areas a severity level of 10 V/m may be used.

Note 2: For large apparatus (e.g. traction drives, auxiliary converters) it is often not practical to perform the immunity test to radiated electromagnetic fields on the complete unit. In such cases the manufacturer should test susceptible sub-systems (e.g. control electronics). The test report should justify the selection or not of sub-systems and any assumptions made (e.g. reduction of field due to case shielding).

**Note:**

1. There is no deviation to the applied test methods and requirements covered by the scope of this report.
2. The above EN basic standards are applied with latest version if customer has no special requirement.
3. Determining compliance based on the results of the compliance measurement, not taking into account measurement instrumentation uncertainty.
4. N/A: Not Applicable

## 2.1 Performance Criteria

### General Performance Criteria

The general performance criteria apply for those ports for which no specific performance criteria are defined (e.g. auxiliary ports) in the report.

**Performance criterion A:** The apparatus shall continue to operate as intended during and after the test. No degradation of performance or loss of function is allowed below a performance level specified by the manufacturer, when the apparatus is used as intended. The performance level may be replaced by a permissible loss of performance. If the minimum performance level or the permissible performance loss is not specified by the manufacturer, either of these may be derived from the product description and documentation, and from what the user may reasonably expect from the apparatus if used as intended..

**Performance criterion B:** The apparatus shall continue to operate as intended after the test. No degradation of performance or loss of function is allowed below a performance level specified by the manufacturer, when the apparatus is used as intended. The performance level may be replaced by a permissible loss of performance. During the test, degradation of performance is however allowed. No change of actual operating state or stored data is allowed. If the minimum performance level or the permissible performance loss is not specified by the manufacturer, either of these may be derived from the product description and documentation, and from what the user may reasonably expect from the apparatus if used as intended.

**Performance criterion C:** Temporary loss of function is allowed, provided the function is selfrecoverable or can be restored by the operation of the controls.

## 2.2 Measurement Uncertainty

Where relevant, the following measurement uncertainty levels have been estimated for tests performed on the EUT as specified in CISPR 16-4-2:

Measurement	Expanded Uncertainty (k=2) ( $\pm$ )	Maximum allowable uncertainty ( $\pm$ )
Conducted disturbance at mains port using AMN, 150kHz ~ 30MHz	2.79 dB	3.4 dB ( $U_{\text{cispr}}$ )
Radiated disturbance, 30MHz ~ 1GHz	3.91 dB	6.3 dB ( $U_{\text{cispr}}$ )
Radiated disturbance, 1GHz ~ 6GHz	5.12 dB	5.2 dB ( $U_{\text{cispr}}$ )

The other instruments specified are routine verified to remain within the calibrated levels, no measurement uncertainty is required to be calculated.

## 2.3 Modification Record

There were no modifications required for compliance.



### 3 General Information

#### 3.1 Description of EUT

Product	SPC-4000 series
Brand	Vecow
Test Model	SPC-4020A
Series Model	SPC-4XXXXXXXXXXXXXXXXX ("X" can be 0-9, A-Z or blank for marketing purpose)
Model Difference	Marketing Differentiation
Sample Status	Engineering sample
Operating Software	Windows 10
Power Supply Rating	9-36V, DC-in
Accessory Device	Adapter
Data Cable Supplied	N/A

Note:

1. The EUT is a SPC-4000 series with following interfaces:

- ✧ COM (RS232/422/485)\*4
- ✧ USB 2.0\*2
- ✧ USB 3.0\*2
- ✧ Isolated DIO
- ✧ HDMI (resolution up to 3480 x 2160 @ 30Hz)
- ✧ VGA (resolution up to 1920 x 1440 @ 60Hz)
- ✧ Line out
- ✧ Mic. in
- ✧ LAN (10/100/1000Mbps)\*2
- ✧ Switch
- ✧ DC input

2. The EUT uses following adapter.

Brand	MW
Model	GST280A12
Input Power	100-240Vac, 50/60Hz, 4.5A
Output Power	12V, 21A, 252W
Power Line	Non-shielded DC (1.0m) with two ferrite cores

#### 3.2 Features of EUT

1. The tests reported herein were performed according to the method specified by Vecow Co., Ltd., for detailed feature description, please refer to the manufacturer's specifications or user's manual.

2. The EUT was configured with the following key components:

Processor	Intel Atom® x7-E3950 Processor (Apollo Lake-I)
BIOS	AMI
SIO	IT8786E
Memory	1 DDR3L 1866MHz SO-DIMM, up to 8GB
OS	Windows 10, Linux

### 3.3 Operating Modes of EUT and Determination of Worst Case Operating Mode

- The EUT is designed with AC power of rating 100-240Vac, 50/60Hz.  
For radiated emission evaluation, 230Vac/50Hz (EN 50121-3-2), 230Vac/50Hz & 110Vac/60Hz (EN 55032), 120Vac/60Hz (for FCC Part 15) had been covered during the pre-test. The worst data was found at **110Vac/60Hz** and recorded in the applied test report.
- Test modes are presented in the report as below.

Mode	Test Condition	Input Power
Conducted emission test		
1	Full system, HDMI (3480 x 2160 @ 30Hz)+ VGA* (1920x 1200 @ 60Hz)	230Vac/ 50Hz
Radiated emission test		
1	Full system, HDMI (3480 x 2160 @ 30Hz)+ VGA* (1920x 1200 @ 60Hz)	110Vac/60Hz
Immunity tests		
1	Full system, HDMI (3480 x 2160 @ 30Hz)+ VGA* (1920x 1200 @ 60Hz)	230Vac/ 50Hz

**Note: \*The maximum resolution of the external display monitor is 1920x 1200 @ 60Hz.**

### 3.4 Test Program Used and Operation Descriptions

#### Emission tests:

- a. Turned on the power of all equipment.
- b. EUT ran a test program to enable all functions.
- c. EUT read and wrote messages from/to SSD and ext. HDD.
- d. EUT sent and received messages to/from Notebook PCs (kept in a remote area) via two LAN cables.
- e. EUT sent "H" messages to ext. LCD Monitors. Then they displayed "H" patterns on their screens simultaneously.
- f. EUT sent 1kHz audio signal to earphone.
- g. EUT sent messages to modem.
- h. EUT sent messages to printer and printer printed them out.
- i. Steps c-h were repeated.

#### Immunity tests:

- a. Turned on the power of all equipment.
- b. EUT ran a test program to enable all functions.
- c. EUT read and wrote messages from/to SSD and ext. USB flashes.
- d. EUT sent and received messages to/from Notebook PCs (kept in a remote area) via two UTP LAN cables.
- e. EUT sent and received messages to/from Notebook PCs (kept in a remote area) via two STP LAN cables. (For CS test only)
- f. EUT sent "H" messages to ext. LCD Monitors. Then they displayed "H" patterns on their screens simultaneously.
- g. EUT sent audio signal to speaker.
- h. EUT sent messages to modem.
- i. Steps c-h were repeated.

### 3.5 Primary Clock Frequencies of Internal Source

The highest frequency generated or used within the EUT or on which the EUT operates or tunes is 1600 MHz, provided by Vecow Co., Ltd., for detailed internal source, please refer to the manufacturer's specifications.

## 4 Configuration and Connections with EUT

### 4.1 Connection Diagram of EUT and Peripheral Devices

Emission tests:

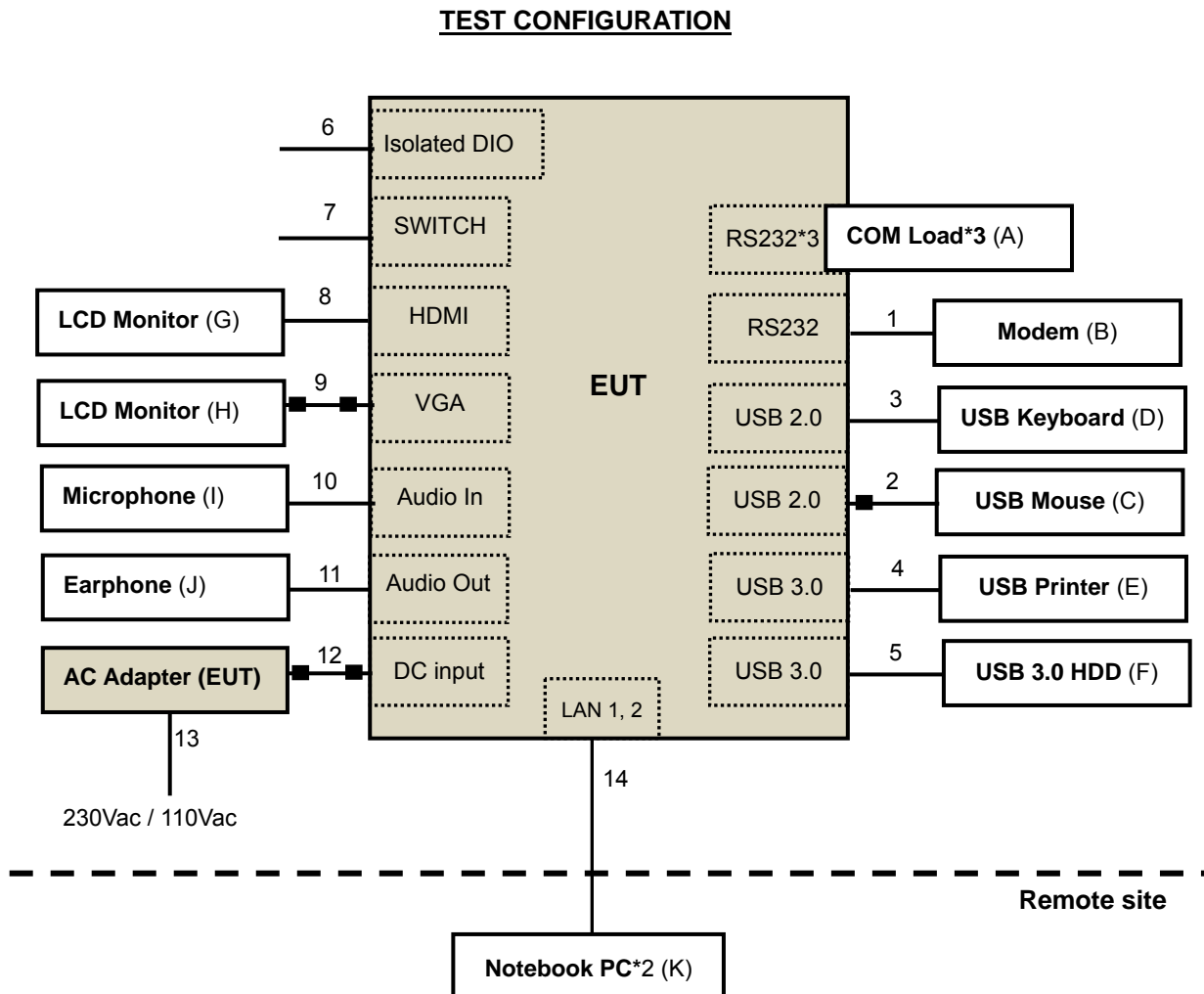

Immunity tests:

**TEST CONFIGURATION**

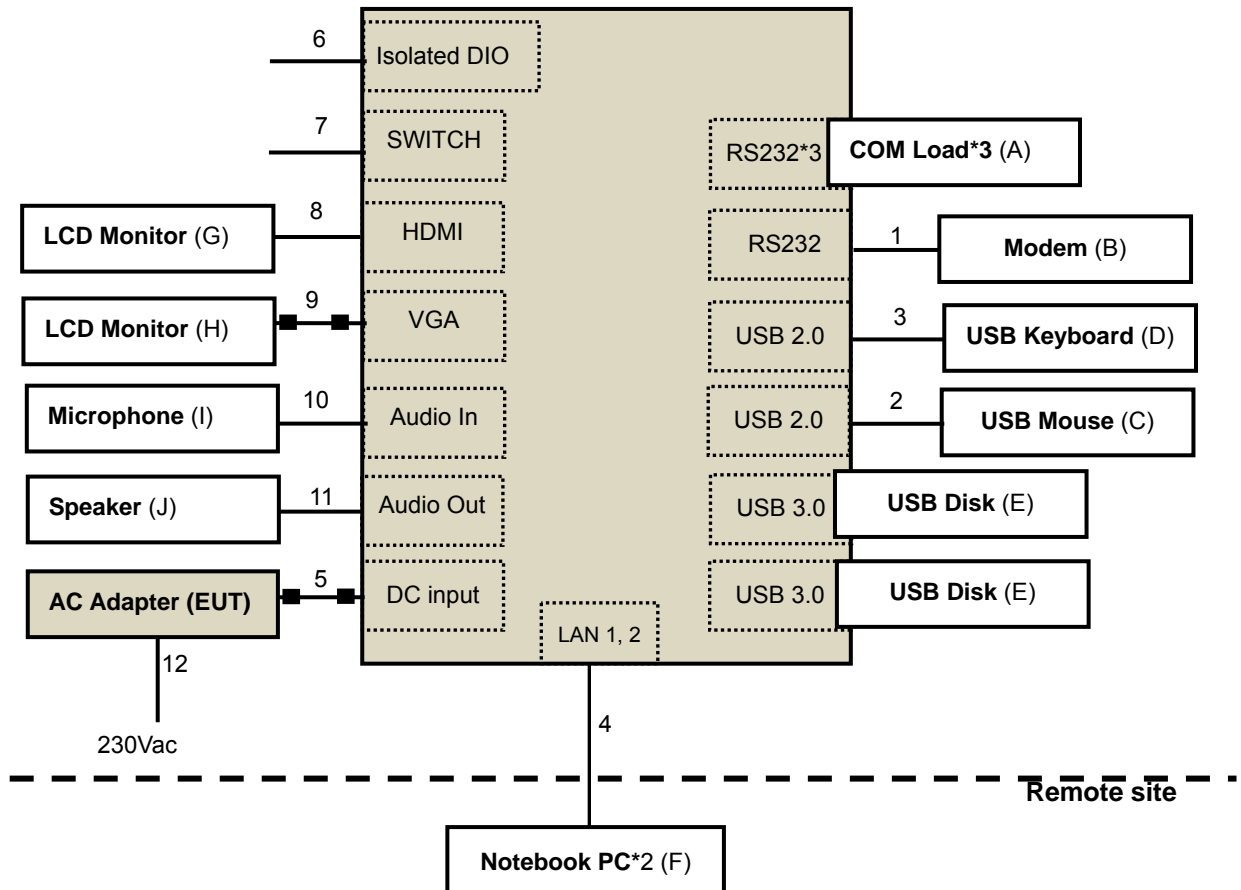

## 4.2 Configuration of Peripheral Devices and Cable Connections

### Emission tests:

ID	Product	Brand	Model No.	Serial No.	FCC ID	Remarks
A.	COM Load*3	N/A	N/A	N/A	N/A	Provided by Lab
B.	MODEM	ACEEX	1414	980020531	IFAXDM1414	Provided by Lab
C.	USB Mouse	Microsoft	1113	9170515772204	FCC DoC Approved	Provided by Lab
D.	USB KEYBOARD	Dell	KB216t	CN-0W33XP-LO300-7CL-1907	FCC DoC Approved	Provided by Lab
E.	Printer	HP	Officejet pro 251dw	N/A	B94SDGOB1191	Provided by Lab
F.	USB 3.0 Hard Disk	WD	WDBUZG0010BBK-PESN	WXF1E84H2ASN	FCC DoC Approved	Provided by Lab
G.	LCD Monitor	ASUS	MG28UQ	H8LMTF147971	FCC DoC Approved	Provided by Lab
H.	LCD Monitor	DELL	U2410	CN082WXD728720 CC10NL	FCC DoC Approved	Provided by Lab
I.	MICROPHONE	Labtec	mic-333	N/A	N/A	Provided by Lab
J.	EARPHONE	PHILIPS	SBC HL145	N/A	N/A	Provided by Lab
K.	Notebook PC	DELL	P41G	FT4W952	FCC DoC Approved	Provided by Lab
	Notebook PC	ASUS	PU401L	ECNXBC012528528	FCC DoC Approved	Provided by Lab

### Note:

1. All power cords of the above support units are non-shielded (1.8m).
2. Item K acted as communication partners to transfer data.

ID	Descriptions	Qty.	Length (m)	Shielding (Yes/No)	Cores (Qty.)	Remarks
1.	RS232 cable	1	1.2	Y	0	Provided by Lab
2.	USB cable	1	1.8	Y	1	Provided by Lab
3.	USB cable	1	1.8	Y	0	Provided by Lab
4.	USB cable	1	1.8	Y	0	Provided by Lab
5.	USB cable	1	0.5	Y	0	Provided by Lab
6.	Signal cable	1	0.3	N	0	Supplied by client
7.	Signal cable	1	0.7	N	0	Supplied by client
8.	HDMI cable	1	2.0	Y	0	Provided by Lab
9.	D-Sub cable	1	1.8	Y	2	Provided by Lab
10.	Audio cable	1	1.2	N	0	Provided by Lab
11.	Audio cable	1	2.2	N	0	Provided by Lab
12.	DC power	1	1.0	N	2	Supplied by client
13.	AC power cord	1	1.8	N	0	Provided by Lab
14.	LAN cable (Cat.5e)	2	10	N	0	Provided by Lab

Note: The core(s) is(are) originally attached to the cable(s).

Immunity tests:

ID	Product	Brand	Model No.	Serial No.	FCC ID	Remarks
A.	COM Load*3	N/A	N/A	N/A	N/A	Provided by Lab
B.	MODEM	ACEEX	1414	0206026741	IFAXDM1414	Provided by Lab
C.	USB Mouse	HP	N910U	N/A	FCC DoC Approved	Provided by Lab
D.	USB KEYBOARD	HP	KU-1060	N/A	FCC DoC Approved	Provided by Lab
E.	USB Hard Disk	SP	N/A	N/A	N/A	Provided by Lab
	USB Hard Disk	SP	N/A	N/A	N/A	Provided by Lab
F.	Notebook PC	LENOVO	TP00057A	R9-0JMLFS16/01	FCC DoC Approved	Provided by Lab
	Notebook PC	LENOVO	T470	PF-0QW0NQ	FCC DoC Approved	Provided by Lab
G.	LCD Monitor	DELL	UP2516DT	CN-03JV40-74445-6 6U-197L	FCC DoC Approved	Provided by Lab
H.	LCD Monitor	DELL	U2412M	CN-07N2FG-TV100- 7BG-039L	FCC DoC Approved	Provided by Lab
I.	MICROPHONE	N/A	N/A	N/A	N/A	Provided by Lab
J.	Speaker	N/A	N/A	N/A	N/A	Provided by Lab

Note:

1. All power cords of the above support units are non-shielded (1.8m).
2. Item F acted as communication partners to transfer data.

ID	Descriptions	Qty.	Length (m)	Shielding (Yes/No)	Cores (Qty.)	Remarks
1.	RS232 cable	1	1.2	Y	0	Provided by Lab
2.	USB cable	1	1.8	Y	0	Provided by Lab
3.	USB cable	1	1.8	Y	0	Provided by Lab
4.	LAN cable (Cat.5e)	2	10	N	0	Provided by Lab
	LAN cable (Cat.5e)	2	10	Y	0	Provided by Lab <b>(For CS test only)</b>
5.	DC power	1	1.0	N	2	Supplied by client
6.	Signal cable	1	0.3	N	0	Supplied by client
7.	Signal cable	1	0.7	N	0	Supplied by client
8.	HDMI cable	1	1.8	Y	0	Provided by Lab
9.	D-Sub cable	1	1.8	Y	2	Provided by Lab
10.	Audio cable	1	1.2	N	0	Provided by Lab
11.	Audio cable	1	1.2	N	0	Provided by Lab
12.	AC power cord	1	1.8	N	0	Provided by Lab

Note: The core(s) is(are) originally attached to the cable(s).

## 5 Conducted Disturbance at Auxiliary a.c. or d.c. Power Ports

### 5.1 Limits

Frequency (MHz)	Quasi-peak, (dBuV)
0.15 - 0.5	99
0.5 - 30	93

Notes: 1. The lower limit shall apply at the transition frequencies.  
 2. The limit decreases linearly with the logarithm of the frequency in the range of 0.15 to 0.50 MHz.

### 5.2 Test Instruments

Description & Manufacturer	Model No.	Serial No.	Cal. Date	Cal. Due
ROHDE & SCHWARZ TEST RECEIVER	ESR3	102414	Jan. 17, 2019	Jan. 16, 2020
ROHDE & SCHWARZ Artificial Mains Network (for EUT)	ENV216	101197	May 23, 2018	May 22, 2019
LISN With Adapter (for EUT)	AD10	C10Ada-002	May 23, 2018	May 22, 2019
ROHDE & SCHWARZ Artificial Mains Network (for peripherals)	ESH3-Z5	100218	Nov. 30, 2018	Nov. 29, 2019
SCHWARZBECK Artificial Mains Network (For EUT)	NNLK8129	8129229	May 3, 2018	May 2, 2019
SCHWARZBECK Artificial Mains Network (For EUT)	NNLK 8121	8121-808	Mar. 15, 2019	Mar. 14, 2020
Software	Cond_V7.3.7.4	NA	NA	NA
RF cable (JYEBAO) With 10dB PAD	5D-FB	Cable-C10.01	Feb. 13, 2019	Feb. 12, 2020
SUHNER Terminator (For ROHDE & SCHWARZ LISN)	65BNC-5001	E1-011484	May 8, 2018	May 7, 2019
ROHDE & SCHWARZ Artificial Mains Network (For TV EUT)	ESH3-Z5	100220	Nov. 21, 2018	Nov. 20, 2019
LISN With Adapter (for TV EUT)	100220	NA	Nov. 21, 2018	Nov. 20, 2019

Note: 1. The calibration interval of the above test instruments is 12 months and the calibrations are traceable to NML/ROC and NIST/USA.  
 2. The test was performed in Shielded Room No. 10.  
 3. The VCCI Site Registration No. C-11852.  
 4. Tested Date: Apr. 11, 2019



### 5.3 Test Arrangement

- The EUT was placed 0.4 meters from the conducting wall of the shielded room with EUT being connected to the power mains through a line impedance stabilization network (LISN). Other support units were connected to the power mains through another LISN. The two LISNs provide 50 Ohm/ 50uH of coupling impedance for the measuring instrument.
- Both lines of the power mains connected to the EUT were checked for maximum conducted interference.
- The test results of conducted emissions at mains ports are recorded of six worst margins for quasi-peak (mandatory) [and average (if necessary)] values against the limits at frequencies of interest unless the margin is 20 dB or greater.

Note: The resolution bandwidth and video bandwidth of test receiver is 9kHz for quasi-peak detection (QP) and average detection (AV) at frequency 0.15MHz-30MHz.

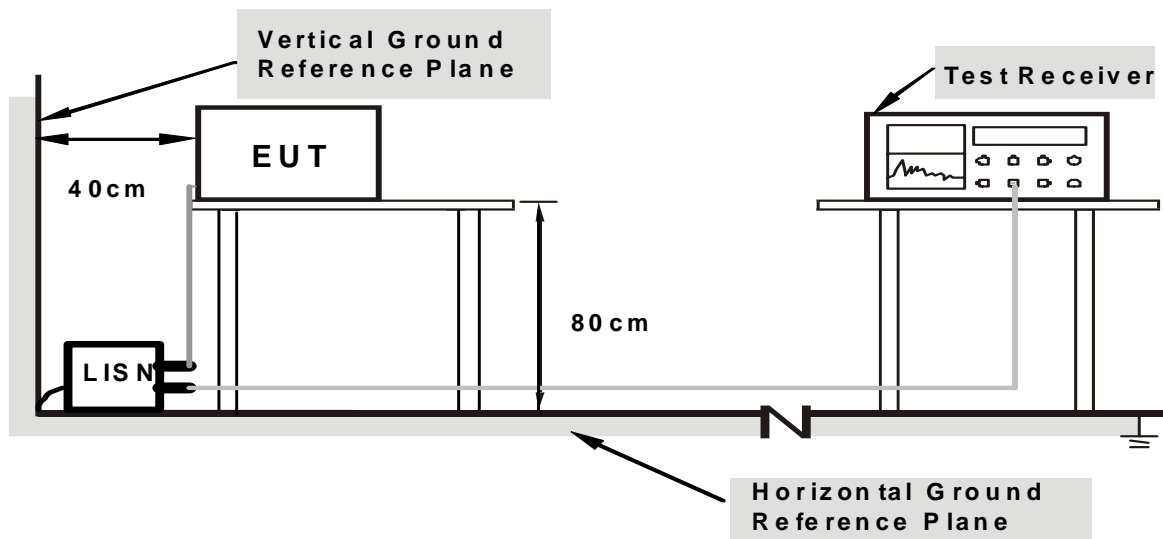

**Note: Support units were connected to second LISN.**

For the actual test configuration, please refer to the related item – Photographs of the Test Configuration.

## 5.4 Test Results

<b>Frequency Range</b>	150kHz ~ 30MHz	<b>Detector Function &amp; Bandwidth</b>	Quasi-Peak (QP), 9kHz
<b>Input Power</b>	230Vac, 50Hz	<b>Environmental Conditions</b>	25°C, 69%RH
<b>Tested by</b>	Mick Chou		
<b>Test Mode</b>	Mode 1		

Phase Of Power : Line (L)						
No	Frequency (MHz)	Correction Factor (dB)	Reading Value (dBuV)	Emission Level (dBuV)	Limit (dBuV)	Margin (dB)
			Q.P.	Q.P.	Q.P.	Q.P.
1	0.23602	9.68	25.47	35.15	99.00	-63.85
2	0.66422	9.73	29.35	39.08	93.00	-53.92
3	0.71505	9.73	34.03	43.76	93.00	-49.24
4	7.62361	9.90	27.90	37.80	93.00	-55.20
5	11.76821	9.97	27.14	37.11	93.00	-55.89
<b>6</b>	<b>13.99300</b>	<b>9.99</b>	<b>35.86</b>	<b>45.85</b>	<b>93.00</b>	<b>-47.15</b>

### Remarks:

1. Q.P. and AV. are abbreviations of quasi-peak and average individually.
2. The emission levels of other frequencies were very low against the limit.
3. Margin value = Emission level – Limit value
4. Correction factor = Insertion loss + Cable loss
5. Emission Level = Correction Factor + Reading Value

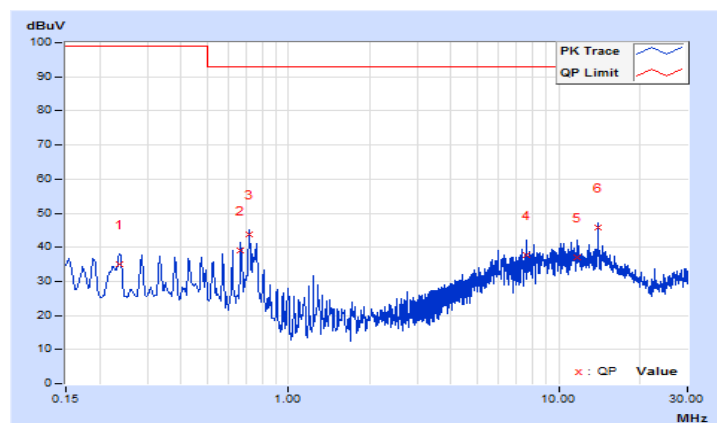

<b>Frequency Range</b>	150kHz ~ 30MHz	<b>Detector Function &amp; Bandwidth</b>	Quasi-Peak (QP), 9kHz
<b>Input Power</b>	230Vac, 50Hz	<b>Environmental Conditions</b>	25°C, 69%RH
<b>Tested by</b>	Mick Chou		
<b>Test Mode</b>	Mode 1		

Phase Of Power : Neutral (N)						
No	Frequency (MHz)	Correction Factor (dB)	Reading Value (dBuV)	Emission Level (dBuV)	Limit (dBuV)	Margin (dB)
			Q.P.	Q.P.	Q.P.	Q.P.
1	0.23898	9.69	26.91	36.60	99.00	-62.40
2	0.42761	9.71	25.17	34.88	99.00	-64.12
3	0.66604	9.74	31.30	41.04	93.00	-51.96
4	0.71505	9.75	33.92	43.67	93.00	-49.33
5	11.00576	9.98	30.70	40.68	93.00	-52.32
6	14.05165	10.02	32.75	42.77	93.00	-50.23

**Remarks:**

1. Q.P. and AV. are abbreviations of quasi-peak and average individually.
2. The emission levels of other frequencies were very low against the limit.
3. Margin value = Emission level – Limit value
4. Correction factor = Insertion loss + Cable loss
5. Emission Level = Correction Factor + Reading Value

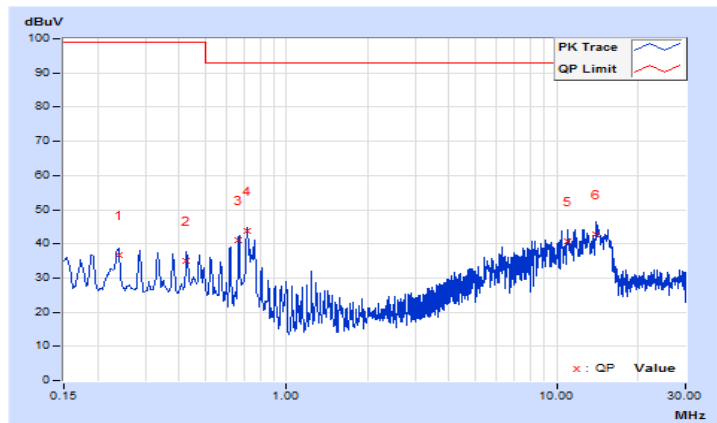

## 6 Radiated Disturbance up to 1 GHz

### 6.1 Limits

Frequency (MHz)	dBuV/m (at 10m) / quasi-peak
30 - 230	40
230 - 1000	47

- Notes:
1. The lower limit shall apply at the transition frequencies.
  2. Emission level (dBuV/m) = 20 log Emission level (uV/m).
  3. All emanations from a class A/B digital device or system, including any network of conductors and apparatus connected thereto, shall not exceed the level of field strengths specified above.

### 6.2 Test Instruments

Description & Manufacturer	Model No.	Serial No.	Cal. Date	Cal. Due
ROHDE & SCHWARZ TEST RECEIVER	ESCI	100744	May 7, 2018	May 6, 2019
Schaffner BILOG Antenna	CBL6111D	22270	Nov. 21, 2018	Nov. 20, 2019
Sonoma Preamplifier	310N	352921	Feb. 19, 2019	Feb. 18, 2020
CT Turn Table	TT100	CT-080	NA	NA
CT Tower	AT100	CT-080	NA	NA
Software	Radiated_V7.6.15.9.5	NA	NA	NA
ANRITSU RF Switches	MP59B	NA	Mar. 6, 2019	Mar. 5, 2020
WOKEN RF cable With 5dB PAD	8D	CABLE-ST3-01	Mar. 6, 2019	Mar. 5, 2020

- Note:
1. The calibration interval of the above test instruments is 12 months and the calibrations are traceable to NML/ROC and NIST/USA.
  2. The test was performed in Open Site No. 3.
  3. The VCCI Site Registration No. is R-269.
  4. Tested Date: Apr. 10, 2019

### 6.3 Test Arrangement

- The EUT was placed on the top of a rotating table 0.8 meters above the ground at an accredited test facility. The table was rotated 360 degrees to determine the position of the highest radiation.
- The EUT was set 10 meters away from the interference-receiving antenna, which was mounted on the top of a variable-height antenna tower.
- The antenna is a broadband antenna, and its height is varied from one meter to four meters above the ground to determine the maximum value of the field strength. Both horizontal and vertical polarizations of the antenna are set to make the measurement.
- For each suspected emission, the EUT was arranged to its worst case and then the antenna was tuned to heights from 1 meter to 4 meters and the rotatable table was turned from 0 degrees to 360 degrees to find the maximum reading.
- The test-receiver system was set to quasi-peak detect function and specified bandwidth with maximum hold mode when the test frequency is up to 1 GHz.

Note: The resolution bandwidth and video bandwidth of test receiver/spectrum analyzer is 120kHz for quasi-peak detection (QP) at frequency up to 1GHz.

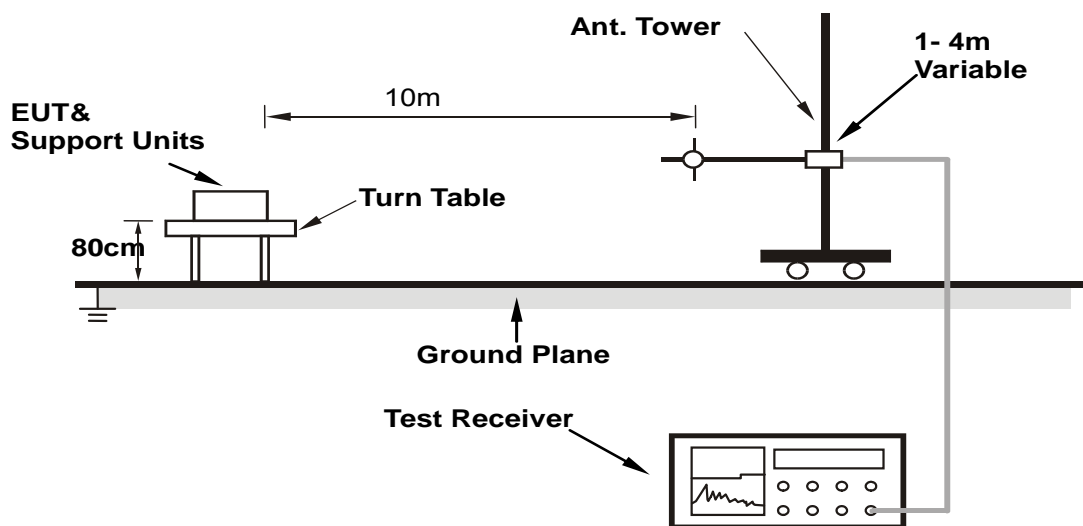

For the actual test configuration, please refer to the related item – Photographs of the Test Configuration.

### 6.4 Test Results

<b>Frequency Range</b>	30MHz ~ 1GHz	<b>Detector Function &amp; Bandwidth</b>	Quasi-Peak (QP), 120kHz
<b>Tested by</b>	Vhenson Huang	<b>Environmental Conditions</b>	27°C, 60%RH
<b>Test Mode</b>	Mode 1		

Antenna Polarity & Test Distance : Horizontal at 10 m								
No	Frequency (MHz)	Emission Level (dBuV/m)	Limit (dBuV/m)	Margin (dB)	Antenna Height (m)	Table Angle (Degree)	Raw Value (dBuV)	Correction Factor (dB/m)
1	58.85	26.58 QP	40.00	-13.42	4.00 H	127	47.30	-20.72
2	124.51	35.36 QP	40.00	-4.64	4.00 H	110	49.56	-14.20
3	144.83	35.03 QP	40.00	-4.97	4.00 H	223	49.17	-14.14
4	169.59	37.30 QP	40.00	-2.70	4.00 H	243	52.52	-15.22
5	177.53	37.58 QP	40.00	-2.42	4.00 H	193	53.00	-15.42
6	185.47	37.69 QP	40.00	-2.31	4.00 H	161	53.15	-15.46
7	193.72	35.74 QP	40.00	-4.26	4.00 H	126	51.12	-15.38
8	218.28	35.18 QP	40.00	-4.82	4.00 H	116	49.98	-14.80
<b>9</b>	<b>224.34</b>	<b>37.94 QP</b>	<b>40.00</b>	<b>-2.06</b>	<b>4.00 H</b>	<b>284</b>	<b>52.42</b>	<b>-14.48</b>
10	232.54	42.95 QP	47.00	-4.05	3.86 H	209	56.93	-13.98
11	250.73	43.35 QP	47.00	-3.65	3.71 H	73	55.61	-12.26
12	259.25	44.28 QP	47.00	-2.72	3.25 H	294	55.68	-11.40
13	275.27	43.36 QP	47.00	-3.64	3.18 H	114	55.45	-12.09
<b>14</b>	<b>295.64</b>	<b>44.94 QP</b>	<b>47.00</b>	<b>-2.06</b>	<b>3.08 H</b>	<b>110</b>	<b>56.34</b>	<b>-11.40</b>
15	439.52	37.98 QP	47.00	-9.02	2.13 H	246	45.17	-7.19
16	890.94	40.98 QP	47.00	-6.02	1.00 H	205	40.20	0.78

Remarks:

1. Emission Level(dBuV/m) = Raw Value(dBuV) + Correction Factor(dB/m)
2. Correction Factor(dB/m) = Antenna Factor (dB/m) + Cable Factor (dB) – Pre-Amplifier Factor (dB)
3. The other emission levels were very low against the limit.
4. Margin value = Emission level – Limit value

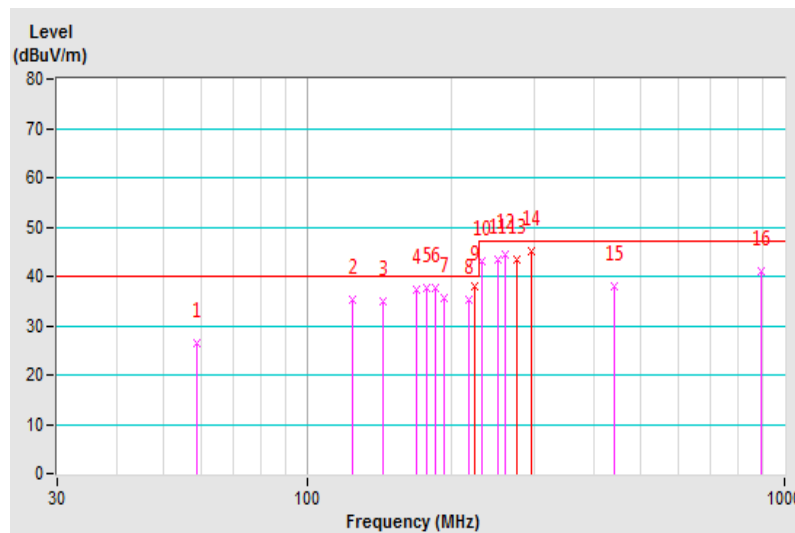

<b>Frequency Range</b>	30MHz ~ 1GHz	<b>Detector Function &amp; Bandwidth</b>	Quasi-Peak (QP), 120kHz
<b>Tested by</b>	Vhenson Huang	<b>Environmental Conditions</b>	27°C, 60%RH
<b>Test Mode</b>	Mode 1		

Antenna Polarity & Test Distance : Vertical at 10 m								
No	Frequency (MHz)	Emission Level (dBuV/m)	Limit (dBuV/m)	Margin (dB)	Antenna Height (m)	Table Angle (Degree)	Raw Value (dBuV)	Correction Factor (dB/m)
1	34.35	32.53 QP	40.00	-7.47	1.52 V	119	43.66	-11.13
2	68.28	30.32 QP	40.00	-9.68	1.28 V	188	50.36	-20.04
3	124.39	34.96 QP	40.00	-5.04	1.00 V	176	49.16	-14.20
4	168.88	35.86 QP	40.00	-4.14	1.00 V	120	51.05	-15.19
5	193.48	35.36 QP	40.00	-4.64	1.00 V	191	50.73	-15.37
6	225.96	37.55 QP	40.00	-2.45	1.00 V	26	51.94	-14.39
7	232.34	42.45 QP	47.00	-4.55	1.00 V	50	56.44	-13.99
8	258.90	43.91 QP	47.00	-3.09	1.00 V	49	55.34	-11.43
9	266.90	43.35 QP	47.00	-3.65	1.00 V	126	55.39	-12.04
10	299.63	43.97 QP	47.00	-3.03	1.00 V	249	55.32	-11.35
11	333.15	40.82 QP	47.00	-6.18	1.00 V	344	51.46	-10.64
12	446.50	38.02 QP	47.00	-8.98	1.54 V	16	45.04	-7.02
13	742.51	36.31 QP	47.00	-10.69	2.67 V	210	37.10	-0.79
14	890.98	42.24 QP	47.00	-4.76	2.14 V	10	41.46	0.78

Remarks:

1. Emission Level(dBuV/m) = Raw Value(dBuV) + Correction Factor(dB/m)
2. Correction Factor(dB/m) = Antenna Factor (dB/m) + Cable Factor (dB) – Pre-Amplifier Factor (dB)
3. The other emission levels were very low against the limit.
4. Margin value = Emission level – Limit value

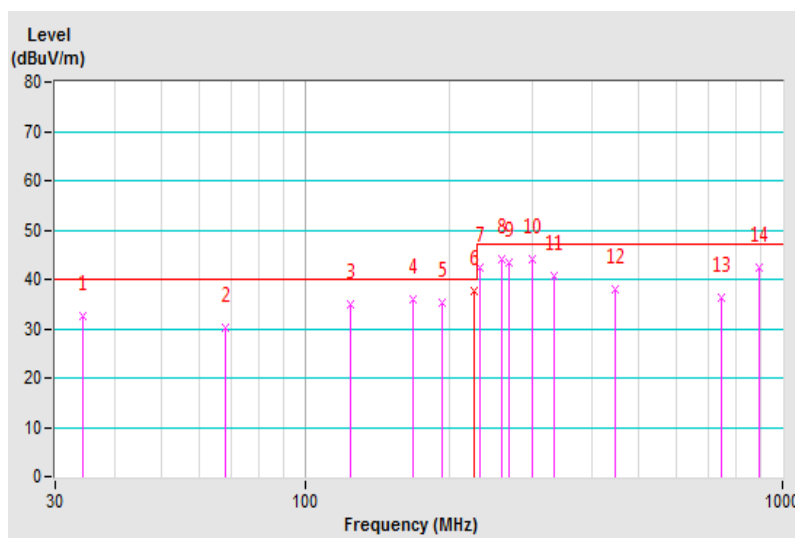

## 7 Radiated Disturbance above 1 GHz

### 7.1 Limits

Frequency (GHz)	dBuV/m (at 3m)	
	Average	Peak
1 to 3	56	76
3 to 6	60	80

- Notes: 1. The lower limit shall apply at the transition frequencies.  
 2. Emission level (dBuV/m) = 20 log Emission level (uV/m).  
 3. All emanations from a class A/B digital device or system, including any network of conductors and apparatus connected thereto, shall not exceed the level of field strengths specified above.

#### Frequency Range (For unintentional radiators)

Highest frequency generated or used in the EUT or on which the EUT operates or tunes (MHz)	Upper frequency of measurement range (MHz)
Below 108	1000
108-500	2000
500-1000	5000
Above 1000	Up to 5 times of the highest frequency or 6 GHz, whichever is less



## 7.2 Test Instruments

Description & Manufacturer	Model No.	Serial No.	Cal. Date	Cal. Due
Agilent Spectrum	E4446A	MY51100009	Jun. 4, 2018	Jun. 3, 2019
Agilent Test Receiver	N9038A	MY50010135	Jun. 23, 2018	Jun. 22, 2019
Agilent Preamplifier	8449B	3008A01924	Feb. 21, 2019	Feb. 20, 2020
MITEQ Preamplifier	AMF-6F-260400-33-8P	892164	Feb. 21, 2019	Feb. 20, 2020
EMCI Preamplifier	EMC184045B	980235	Feb. 21, 2019	Feb. 20, 2020
ETS Preamplifier	3117-PA	00215857	Nov. 25, 2018	Nov. 24, 2019
Schwarzbeck Horn Antenna	BBHA-9170	212	Nov. 25, 2018	Nov. 24, 2019
EMCO Horn Antenna	3115	9312-4192	Nov. 25, 2018	Nov. 24, 2019
Max Full. Turn Table & Tower	MF7802	MF780208103	NA	NA
Software	Radiated_V8.7.08	NA	NA	NA
SUHNER RF cable With 4dB PAD	SF106-18	Cable-CH7-01	Aug. 13, 2018	Aug. 12, 2019
SUHNER RF cable With 3/4dB PAD	SF102	Cable-CH7-3.6m	Aug. 13, 2018	Aug. 12, 2019
MICRO-TRONICS Notch filter	BRC50703-01	010	May 31, 2018	May 30, 2019
MICRO-TRONICS Band Pass Filter	BRM17690	005	May 31, 2018	May 30, 2019

- Note:
1. The calibration interval of the above test instruments is 12 months and the calibrations are traceable to NML/ROC and NIST/USA.
  2. The 3dB beamwidth of the horn antenna is minimum 40 degree (or  $w = 2.18m$  at 3m distance) for 1~6 GHz.
  3. The test was performed in Chamber No. 7.
  4. The VCCI Site Registration No. G-10039
  5. Tested Date: Apr. 11, 2019

### 7.3 Test Arrangement

- The EUT was placed on the top of a rotating table 0.8 meters above the ground at an accredited chamber room. The table was rotated 360 degrees to determine the position of the highest radiation.
- The EUT was set 3 meters away from the interference-receiving antenna, which was mounted on the top of a variable-height antenna tower.
- The height of antenna can be varied from one meter to four meters, the height of adjustment depends on the EUT height and the antenna 3dB beamwidth both, to detect the maximum value of the field strength. Both horizontal and vertical polarizations of the antenna are set to make the measurement.
- For each suspected emission, the EUT was arranged to its worst case and then the antenna was tuned to heights and the rotatable table was turned from 0 degrees to 360 degrees to find the maximum reading.
- The spectrum analyzer system was set to peak and average detect function and specified bandwidth with maximum hold mode when the test frequency is above 1 GHz.

Note: The resolution bandwidth of test receiver/spectrum analyzer is 1MHz and video bandwidth is 3MHz for Peak detection (PK) at frequency above 1GHz. The resolution bandwidth of test receiver/spectrum analyzer is 1 MHz for Average detection (AV) at frequency above 1GHz.

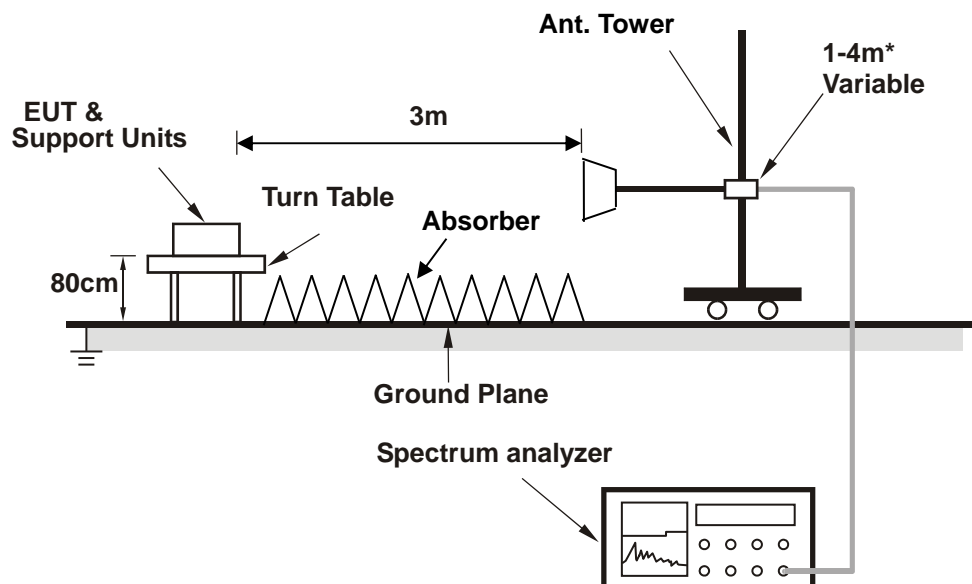

\* :depends on the EUT height and the antenna 3dB beamwidth both.

For the actual test configuration, please refer to the related item – Photographs of the Test Configuration.

### 7.4 Test Results

<b>Frequency Range</b>	1GHz ~ 6GHz	<b>Detector Function &amp; Bandwidth</b>	Peak (PK) / Average (AV), 1MHz
<b>Tested by</b>	Ken Lee	<b>Environmental Conditions</b>	23°C, 71%RH
<b>Test Mode</b>	Mode 1		

Antenna Polarity & Test Distance : Horizontal at 3 m								
No	Frequency (MHz)	Emission Level (dBuV/m)	Limit (dBuV/m)	Margin (dB)	Antenna Height (m)	Table Angle (Degree)	Raw Value (dBuV)	Correction Factor (dB/m)
1	1186.77	53.84 PK	76.00	-22.16	1.00 H	235	59.37	-5.53
2	1186.77	40.30 AV	56.00	-15.70	1.00 H	235	45.83	-5.53
3	1780.07	54.54 PK	76.00	-21.46	2.00 H	217	59.33	-4.79
4	1780.07	40.86 AV	56.00	-15.14	2.00 H	217	45.65	-4.79
5	1999.59	56.27 PK	76.00	-19.73	2.00 H	348	59.94	-3.67
6	1999.59	42.32 AV	56.00	-13.68	2.00 H	348	45.99	-3.67

Remarks:

1. Emission Level(dBuV/m) = Raw Value(dBuV) + Correction Factor(dB/m)
2. Correction Factor(dB/m) = Antenna Factor (dB/m) + Cable Factor (dB) – Pre-Amplifier Factor (dB)
3. The other emission levels were very low against the limit.
4. Margin value = Emission level – Limit value

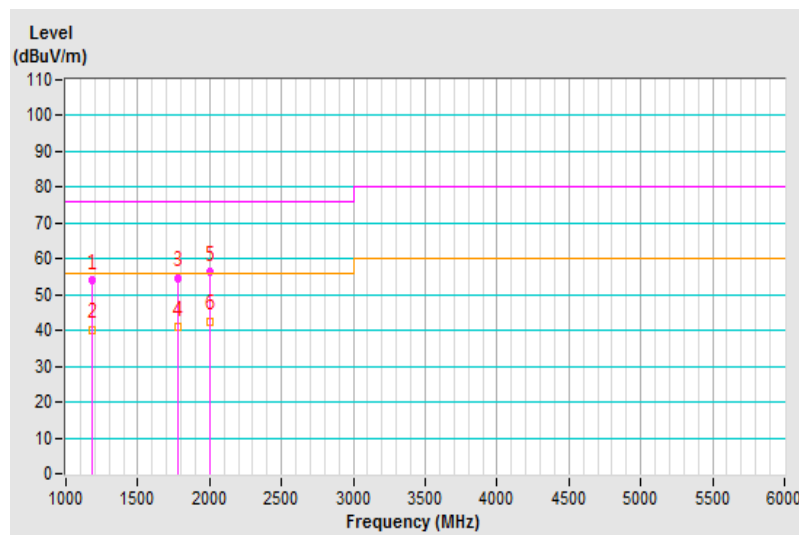

<b>Frequency Range</b>	1GHz ~ 6GHz	<b>Detector Function &amp; Bandwidth</b>	Peak (PK) / Average (AV), 1MHz
<b>Tested by</b>	Ken Lee	<b>Environmental Conditions</b>	23°C, 71%RH
<b>Test Mode</b>	Mode 1		

Antenna Polarity & Test Distance : Vertical at 3 m								
No	Frequency (MHz)	Emission Level (dBuV/m)	Limit (dBuV/m)	Margin (dB)	Antenna Height (m)	Table Angle (Degree)	Raw Value (dBuV)	Correction Factor (dB/m)
1	1186.76	53.86 PK	76.00	-22.14	1.00 V	162	59.39	-5.53
2	1186.76	41.05 AV	56.00	-14.95	1.00 V	162	46.58	-5.53
3	1483.48	56.01 PK	76.00	-19.99	1.88 V	231	61.91	-5.90
4	1483.48	37.87 AV	56.00	-18.13	1.88 V	231	43.77	-5.90
5	1780.07	57.64 PK	76.00	-18.36	1.92 V	210	62.43	-4.79
<b>6</b>	<b>1780.07</b>	<b>43.68 AV</b>	<b>56.00</b>	<b>-12.32</b>	<b>1.92 V</b>	<b>210</b>	<b>48.47</b>	<b>-4.79</b>
7	1995.80	54.61 PK	76.00	-21.39	1.00 V	127	58.28	-3.67
8	1995.80	38.77 AV	56.00	-17.23	1.00 V	127	42.44	-3.67

Remarks:

1. Emission Level(dBuV/m) = Raw Value(dBuV) + Correction Factor(dB/m)
2. Correction Factor(dB/m) = Antenna Factor (dB/m) + Cable Factor (dB) – Pre-Amplifier Factor (dB)
3. The other emission levels were very low against the limit.
4. Margin value = Emission level – Limit value

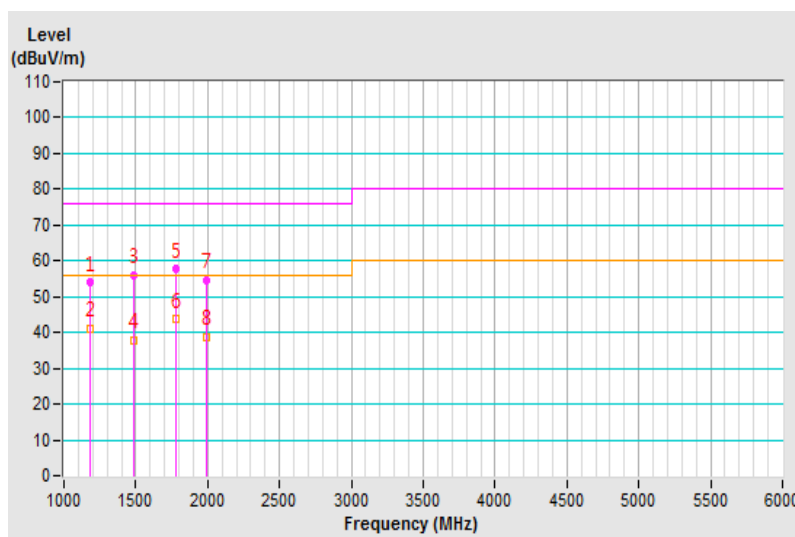

## 8 Electrostatic Discharge Immunity Test (ESD)

### 8.1 Test Specification

<b>Basic Standard:</b>	EN 61000-4-2
<b>Discharge Impedance:</b>	330 ohm / 150 pF
<b>Discharge Voltage:</b>	Air Discharge: $\pm 2, \pm 4, \pm 8$ kV (Direct) Contact Discharge: $\pm 2, \pm 4$ kV, $\pm 6$ kV (Direct/Indirect)
<b>Number of Discharge:</b>	Minimum 20 times at each test point
<b>Discharge Mode:</b>	Single Discharge
<b>Discharge Period:</b>	1-second minimum

### 8.2 Test Instruments

Description & Manufacturer	Model No.	Serial No.	Cal. Date	Cal. Due
KeyTek, ESD Simulator	MZ-15/EC	0504259	Nov. 12, 2018	Nov. 11, 2019

- Note:
1. The calibration interval of the above test instruments is 12 months and the calibrations are traceable to NML/ROC and NIST/USA.
  2. The test was performed in ESD Room No. 1.
  3. Tested Date: Apr. 16, 2019

### 8.3 Test Arrangement

- a. Electrostatic discharges were applied only to those points and surfaces of the EUT that are accessible to users during normal operation.
- b. The test was performed with at least ten single discharges on the pre-selected points in the most sensitive polarity.
- c. The time interval between two successive single discharges was at least 1 second.
- d. The ESD generator was held perpendicularly to the surface to which the discharge was applied and the return cable was at least 0.2 meters from the EUT.
- e. Contact discharges were applied to the non-insulating coating, with the pointed tip of the generator penetrating the coating and contacting the conducting substrate.
- f. Air discharges were applied with the round discharge tip of the discharge electrode approaching the EUT as fast as possible (without causing mechanical damage) to touch the EUT. After each discharge, the ESD generator was removed from the EUT and re-triggered for a new single discharge. The test was repeated until all discharges were complete.
- g. At least ten single discharges (in the most sensitive polarity) were applied to the **Horizontal Coupling Plane** at points on each side of the EUT. The ESD generator was positioned at a distance of 0.1 meters from the EUT with the discharge electrode touching the **HCP**.
- h. At least ten single discharges (in the most sensitive polarity) were applied to the center of one vertical edge of the **Vertical Coupling Plane** in sufficiently different positions that the four faces of the EUT were completely illuminated. The **VCP** (dimensions 0.5m x 0.5m) was placed vertically to and 0.1 meters from the EUT.

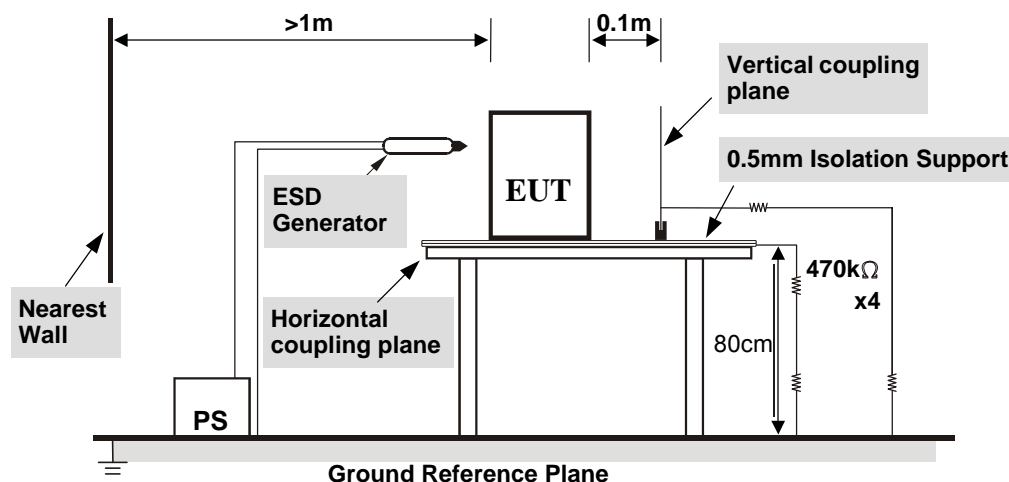

#### TABLE-TOP EQUIPMENT

The configuration consisted of a wooden table 0.8 meters high standing on the **Ground Reference Plane**. The **GRP** consisted of a sheet of aluminum at least 0.25mm thick, and 2.5 meters square connected to the protective grounding system. A **Horizontal Coupling Plane** (1.6m x 0.8m) was placed on the table and attached to the **GRP** by means of a cable with  $940\text{k}\Omega$  total impedance. The equipment under test, was installed in a representative system as described in section 7 of EN 61000-4-2, and its cables were placed on the **HCP** and isolated by an insulating support of 0.5mm thickness. A distance of 1-meter minimum was provided between the EUT and the walls of the laboratory and any other metallic structure.

For the actual test configuration, please refer to the related item – Photographs of the Test Configuration.

#### 8.4 Test Results

Input Power	230 Vac, 50 Hz	Tested by	Chiming Li
Environmental Conditions	23 °C, 43% RH 1011 mbar	Test mode	Mode 1

##### Test Results of Direct Application

Discharge Level (kV)	Polarity (+/-)	Test Point	Contact Discharge	Air Discharge	Performance Criterion
2	+/-	1, 2, 3	Note 1	NA	A
4	+/-	1, 2, 3	Note 2	NA	B
6	+/-	1, 2, 3	Note 2, 3	NA	B
2	+/-	4 ~ 12	NA	Note 1	A
4, 8	+/-	12	NA	Note 1	A
4, 8	+/-	4 ~ 11	NA	Note 2	B

Description of test points of direct application: Please refer to following page for representative mark only.

##### Test Results of Indirect Application

Discharge Level (kV)	Polarity (+/-)	Test Point	Horizontal Coupling Plane	Vertical Coupling Plane	Performance Criterion
2, 4, 6	+/-	Four Sides	Note	Note	A

Description of test points of indirect application:

1. Front side                      2. Rear side                      3. Right side                      4. Left side

- Note: 1. The EUT function was correct during the test.  
 2. There was flicker disturbance on screen during the test, but self-recoverable after the test.  
 3. The transmissions of data from LAN port was delayed 2~3 seconds during the test, but self-recoverable after the test.



### Description of Test Points

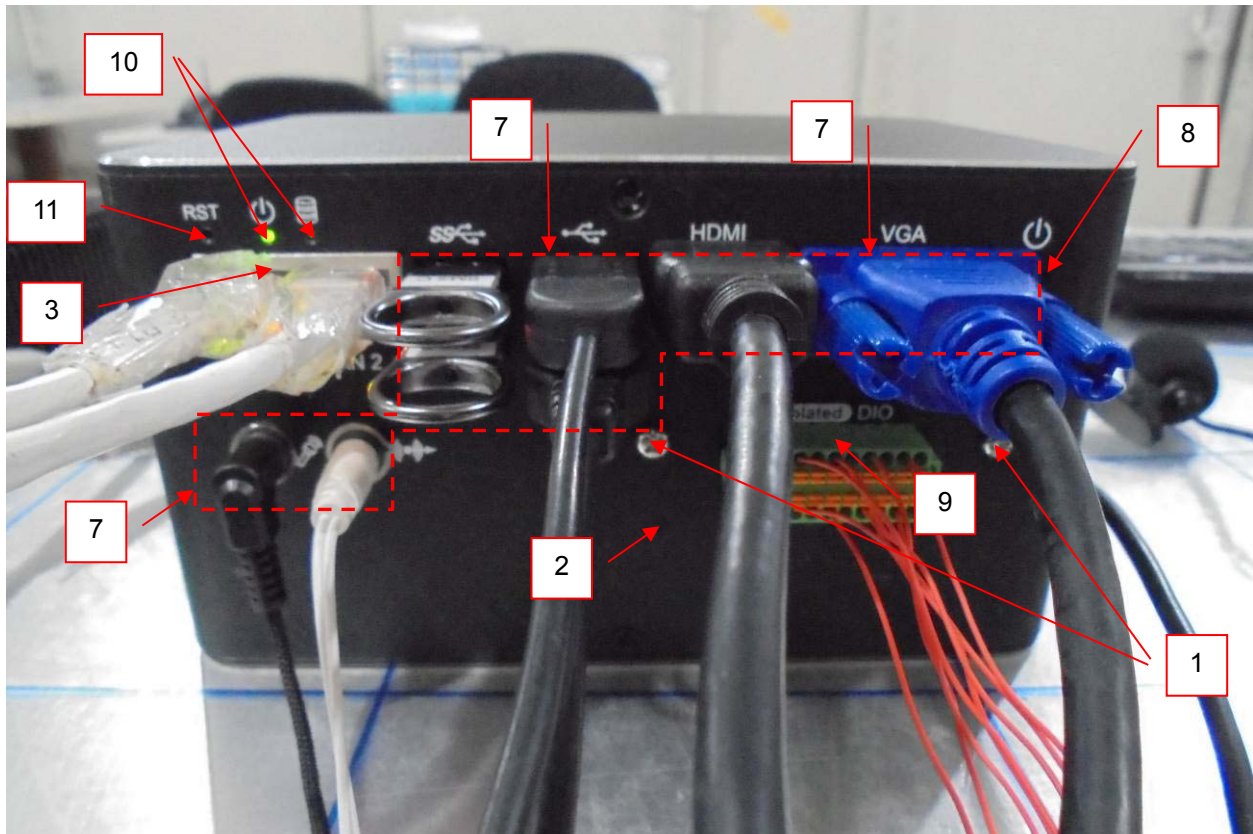
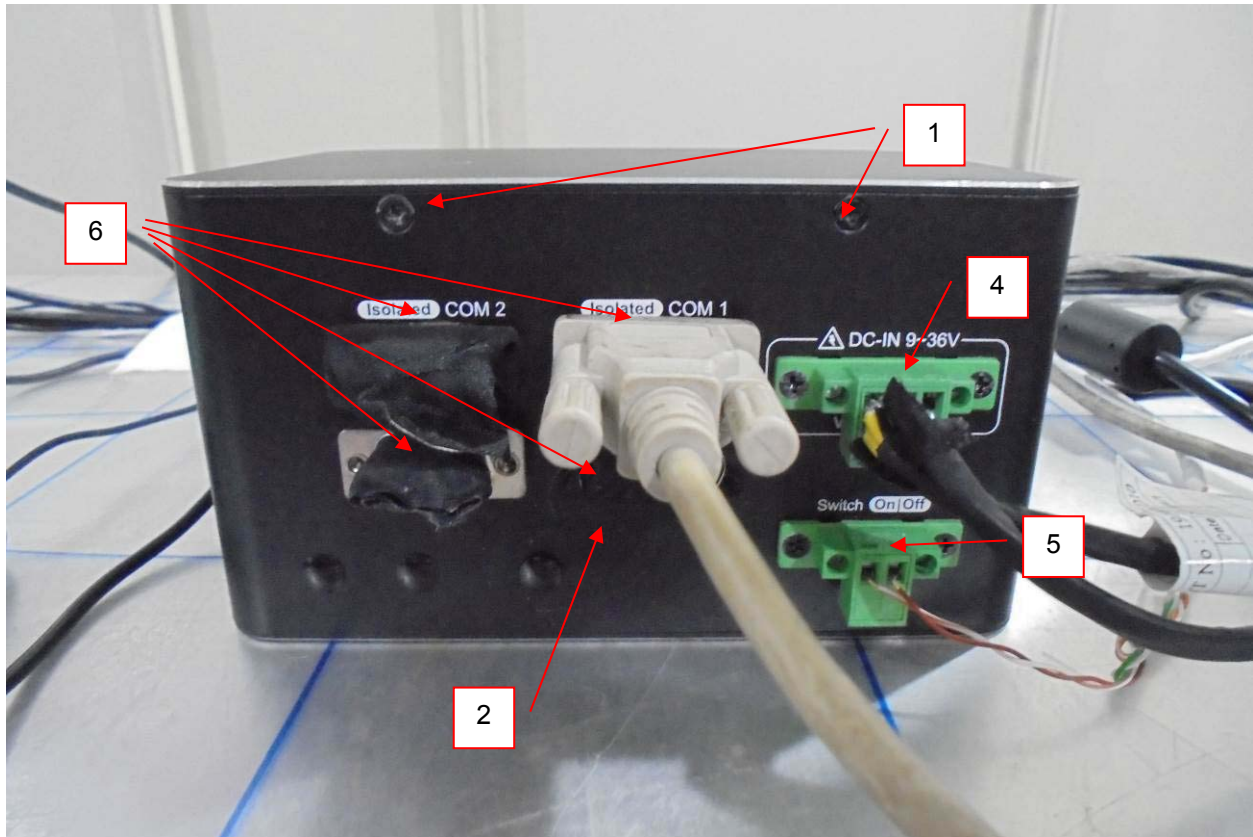



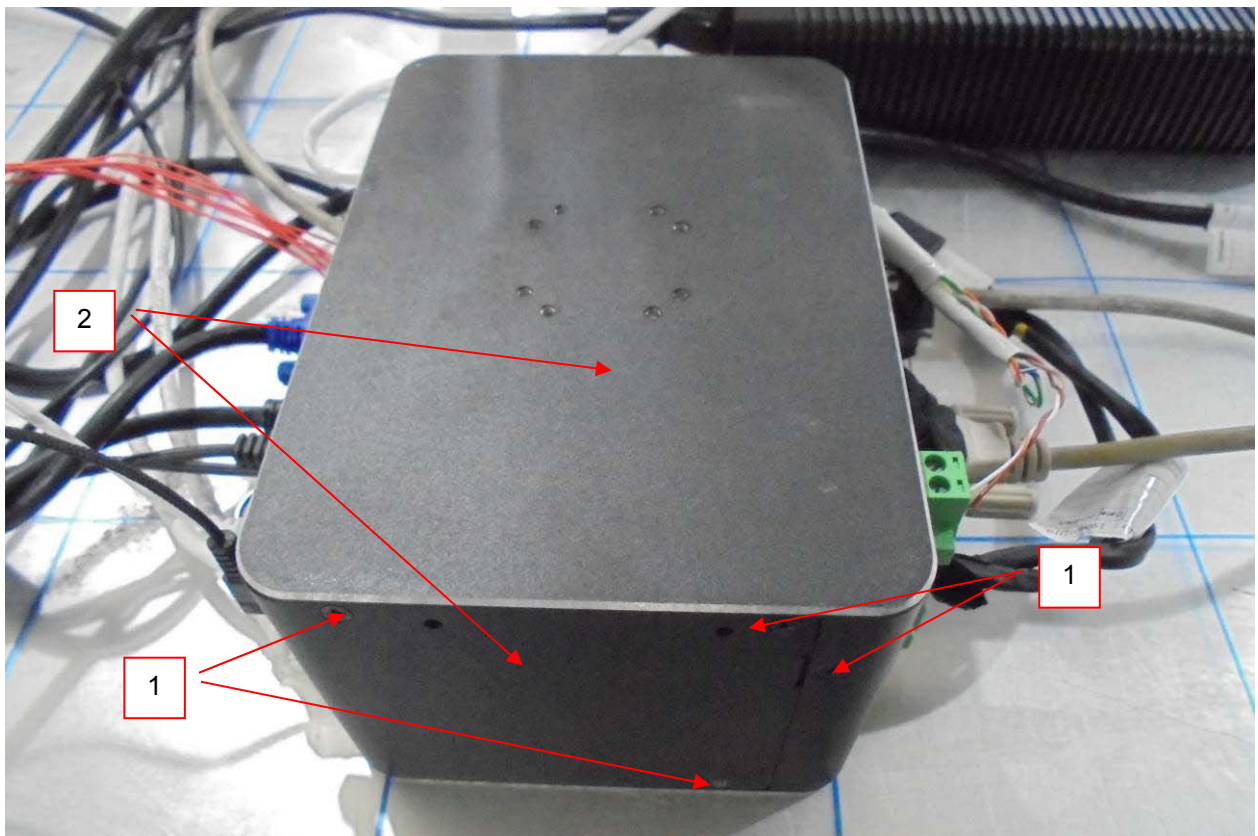
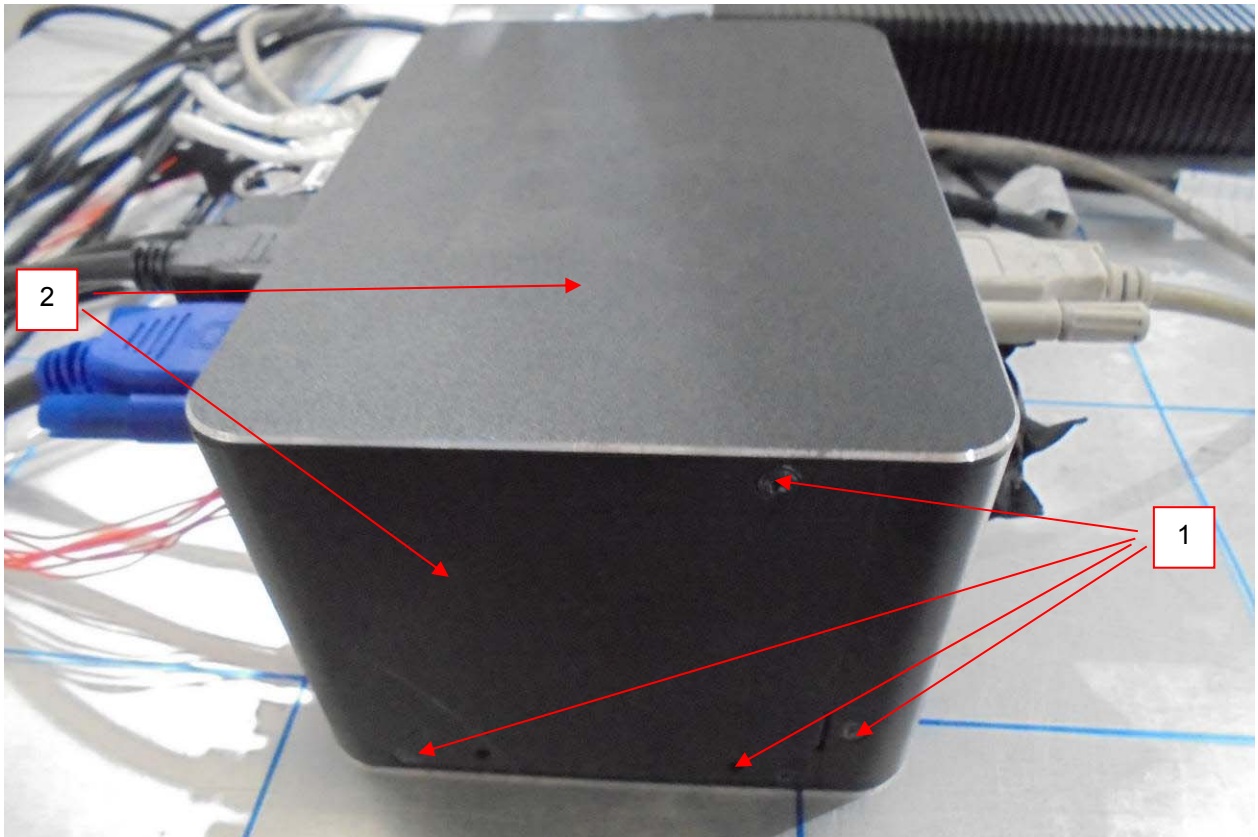

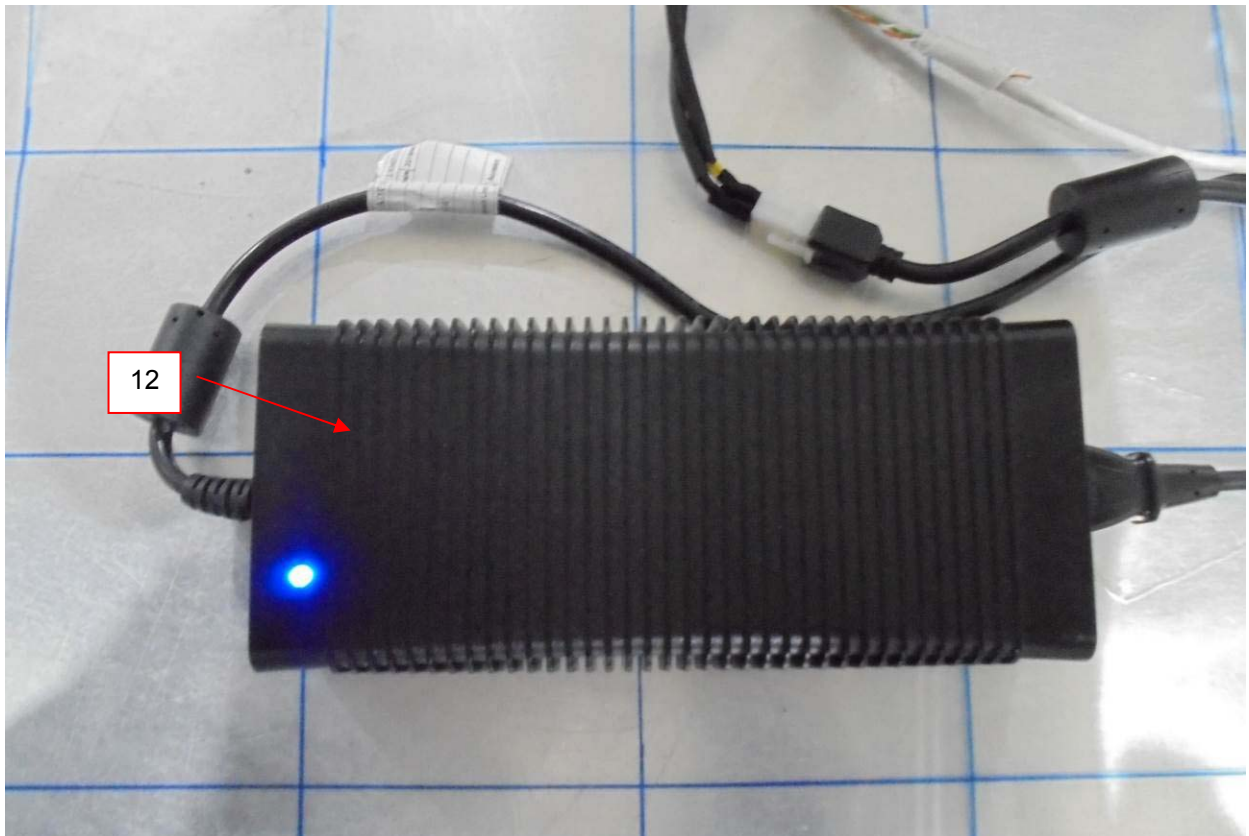

## 9 Radio-frequency Electromagnetic Field Immunity Test (RS)

### 9.1 Test Specification

Basic Standard:	EN 61000-4-3
Frequency Range, Field Strength:	80-800 MHz, 20V/m <sup>1</sup>
	800-1000 MHz, 20V/m
	1400-2000 MHz, 10V/m
	2000-2700 MHz, 5V/m
Modulation:	5100-6000 MHz, 3V/m
	1kHz Sine Wave, 80%, AM Modulation
Frequency Step:	1 % of preceding frequency value
Polarity of Antenna:	Horizontal and Vertical
Antenna Height:	1.5m
Dwell Time:	3 seconds

Note 1: This limit applies to equipment mounted in the passenger compartments, drivers cab or external to the rolling stock (roof, underframe). For equipment mounted in all other areas a severity level of 10 V/m may be used.

### 9.2 Test Instruments

Description & Manufacturer	Model No.	Serial No.	Cal. Date	Cal. Due
Signal Generator KEYSIGHT	N5182B	MY53051971	Oct. 02, 2018	Oct. 01, 2019
Power Amplifier ETS-LINGREN	8100-002	00163537	NA	NA
Power Amplifier ETS-LINGREN	8100-008	00163547	NA	NA
RF Voltage Meter KEYSIGHT	N1914A	MY55326005	Sep. 27, 2018	Sep. 26, 2019
LOG ANTENNA ETS-LINGREN	3150B	00203052	NA	NA
LOG ANTENNA AR	AT5080ANT	309740	NA	NA
HORN ANTENNA ETS-LINGREN	3119	00203652	NA	NA
TILE!(Software) ETS-LINGREN	7.1.3.34	NA	NA	NA

Note:

1. The calibration interval of the above test instruments are 12 months and the calibrations are traceable to NML/ROC and NIST/USA.
2. The test was performed in Chamber RS-1Room. (TAF No.: 2022)
3. The transmit antenna was located at a distance of 3.0 meters from the EUT.
4. Tested Date: Apr. 26, 2019

3.

### 9.3 Test Arrangement

The test procedure was in accordance with EN 61000-4-3.

- a. The testing was performed in a fully anechoic chamber.
- b. The frequency ranges and field strength levels are 80-800 MHz, 20V/m, 800-1000 MHz, 20V/m, 1400-2000 MHz, 10V/m, 2000-2700 MHz, 5V/m and 5100-6000 MHz, 3V/m with the signal 80% amplitude modulated with a 1kHz sine wave.
- c. The test was performed with the EUT exposed to both vertically and horizontally polarized fields on each of the four sides.

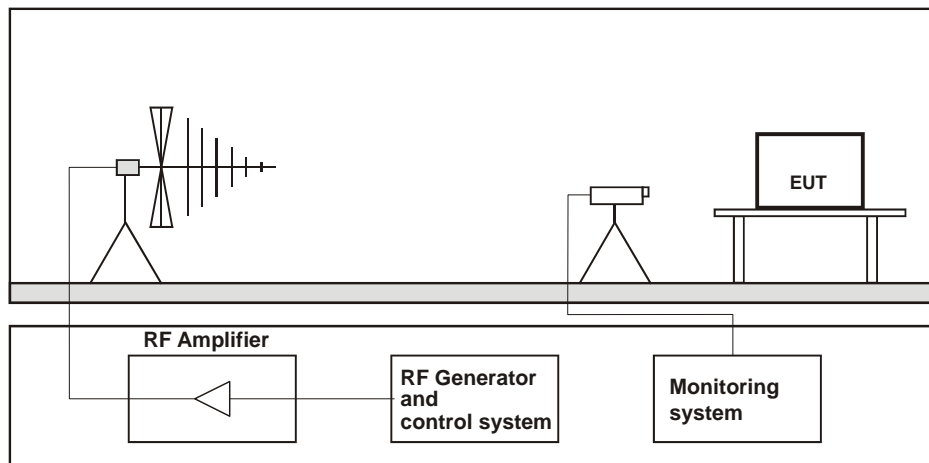

#### Table-top Equipment

The EUT installed in a representative system as described in section 7 of EN 61000-4-3 was placed on a non-conductive table 0.8 meters in height. The system under test was connected to the power and signal wire according to relevant installation instructions.

For the actual test configuration, please refer to the related item – Photographs of the Test Configuration.

#### 9.4 Test Results

Input Power	230 Vac, 50 Hz	Tested by	Vito Lung
Environmental Conditions	23 °C, 70% RH	Test mode	Mode 1

Frequency (MHz)	Polarity	Azimuth(°)	Applied Field Strength		Observation	Test Distance (m)	Performance Criterion
			(V/m)	Modulation			
80 - 800	V&H	0, 90, 180, 270	20	80% AM (1kHz)	Note	3	A
800 - 1000	V&H	0, 90, 180, 270	20	80% AM (1kHz)	Note	3	A
1400 - 2000	V&H	0, 90, 180, 270	10	80% AM (1kHz)	Note	3	A
2000 - 2700	V&H	0, 90, 180, 270	5	80% AM (1kHz)	Note	3	A
5100 - 6000	V&H	0, 90, 180, 270	3	80% AM (1kHz)	Note	3	A

Note: The EUT function was correct during the test.

\* The test, calibration and test results are compliance with the TAF No.: 2022.

## 10 Electrical Fast Transient/Burst Immunity Test (EFT)

### 10.1 Test Specification

Basic Standard:	EN 61000-4-4
Test Voltage:	Signal & communication, process measurement & control ports: $\pm 2\text{kV}$ , Capacitive clamp Battery referenced ports (except at the output of energy sources), Auxiliary a.c. power input ports (rated voltage $\leq 400\text{ Vrms}$ ): $\pm 2\text{kV}$
Impulse Repetition Frequency:	5kHz
Impulse Wave Shape:	5/50 ( $T_r/T_h$ ) ns
Burst Duration:	15 ms
Burst Period:	300 ms
Test Duration:	1 min.

### 10.2 Test Instruments

Description & Manufacturer	Model No.	Serial No.	Cal. Date	Cal. Due
Haefely, EFT Generator	PEFT 4010	154954	Apr. 25, 2018	Apr. 24, 2019
Haefely, Capacitive Clamp	IP4A	155173	Apr. 25, 2018	Apr. 24, 2019

- Note:
1. The calibration interval of the above test instruments is 12 months and the calibrations are traceable to NML/ROC and NIST/USA.
  2. The test was performed in EFT Room.
  3. Tested Date: Apr. 18, 2019



### 10.3 Test Arrangement

- Both positive and negative polarity discharges were applied.
- The distance between any coupling devices and the EUT should be 0.5 m for table-top equipment testing, and 1.0 m for floor standing equipment.
- The duration time of each test sequential was 1 minute.
- The transient/burst waveform was in accordance with EN 61000-4-4, 5/50 ns.

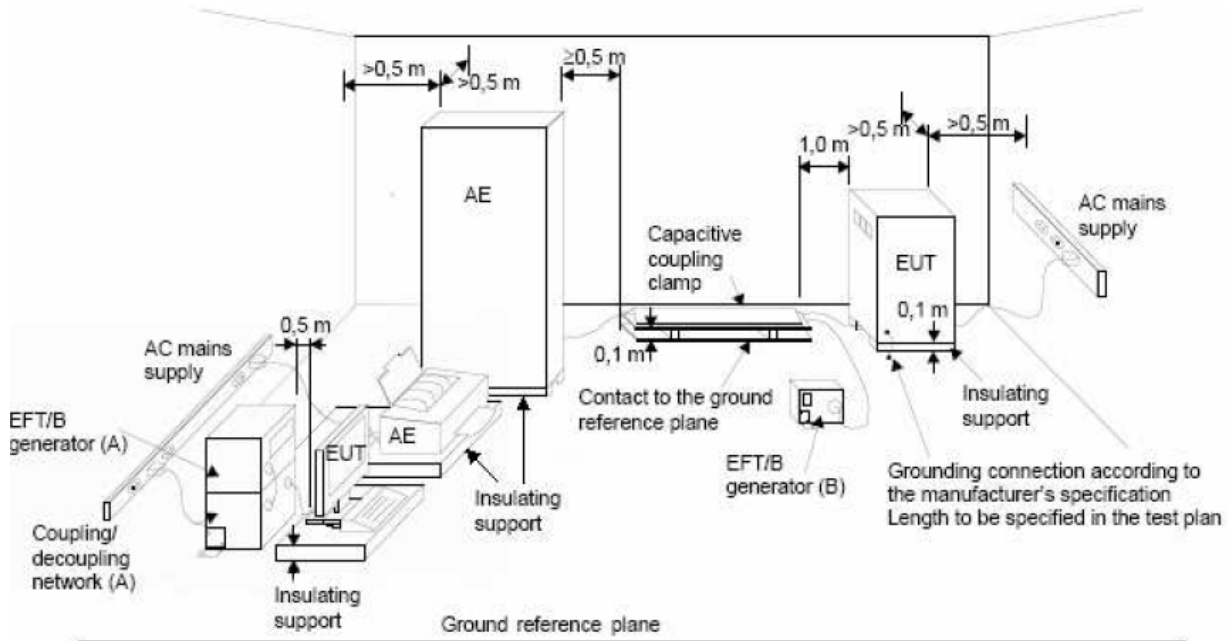

**NOTE:**

- location for supply line coupling
- location for signal lines coupling

For the actual test configuration, please refer to the related item – Photographs of the Test Configuration.

#### 10.4 Test Results

Input Power	230 Vac, 50 Hz	Tested by	Thomas Cheng
Environmental Conditions	23°C, 69% RH	Test mode	Mode 1

##### Auxiliary a.c. power input ports (rated voltage $\leq$ 400 Vrms)

Voltage (kV)	Test Point	Polarity (+/-)	Observation	Performance Criterion
2	L1	+/-	Note	A
2	L2	+/-	Note	A
2	PE	+/-	Note	A
2	L1-L2-PE	+/-	Note	A

##### Signal & communication, process measurement & control ports

Voltage (kV)	Test Point	Polarity (+/-)	Observation	Performance Criterion
2	RJ 45	+/-	Note	A

Note: The EUT function was correct during the test.



## 11 Surge Immunity Test

### 11.1 Test Specification

Basic Standard:	EN 61000-4-5
Wave-Shape:	Battery referenced ports (except at the output of energy sources), Auxiliary a.c. power input ports (rated voltage $\leq 400$ Vrms): 1.2/50 $\mu$ s Open Circuit Voltage 8/20 $\mu$ s Short Circuit Current
Test Voltage:	Line to line: $\pm 0.5$ kV, $\pm 1$ kV, Line to ground: $\pm 0.5$ kV, $\pm 1$ kV, $\pm 2$ kV output impedance of 42 $\Omega$ (40 $\Omega$ and 2 $\Omega$ generator) and a coupling capacitance of 0,5 $\mu$ F
AC Phase Angle (degree):	0°, 90°, 180°, 270°
Pulse Repetition Rate:	1 time / 20 sec.
Number of Tests:	5 positive and 5 negative at selected points

### 11.2 Test Instruments

Description & Manufacturer	Model No.	Serial No.	Cal. Date	Cal. Due
TESEQ, Surge Simulator	NSG 3060	1572	May 28, 2018	May 27, 2019
Coupling Decoupling Network	CDN-UTP8	045	Aug. 27, 2018	Aug. 26, 2019
TESEQ Coupling Decoupling Network	CDN HSS-2	41009	May 23, 2018	May 22, 2019
TESEQ Coupling Decoupling Network	CDN 118-T8	40386	Sep. 20, 2018	Sep. 19, 2019
TESEQ CDN for Unshielded Unsymmetrical Signal & Data Lines	CDN117	40144	Sep. 20, 2018	Sep. 19, 2019

- Note:
1. The calibration interval of the above test instruments is 12 months and the calibrations are traceable to NML/ROC and NIST/USA.
  2. The test was performed in EMS Room No. 2.
  3. Tested Date: Apr. 18, 2019

### 11.3 Test Arrangement

The surge is to be applied to the EUT power supply terminals via the capacitive coupling network. Decoupling networks are required in order to avoid possible adverse effects on equipment not under test that may be powered by the same lines, and to provide sufficient decoupling impedance to the surge wave. The power cord between the EUT and the coupling/decoupling networks shall be 2 meters in length (or shorter).

For double-insulated products without PE or external earth connections, the test shall be done in a similar way as for grounded products but without adding any additional external grounded connections. If there are no other possible connections to earth, line-to-ground tests may be omitted.

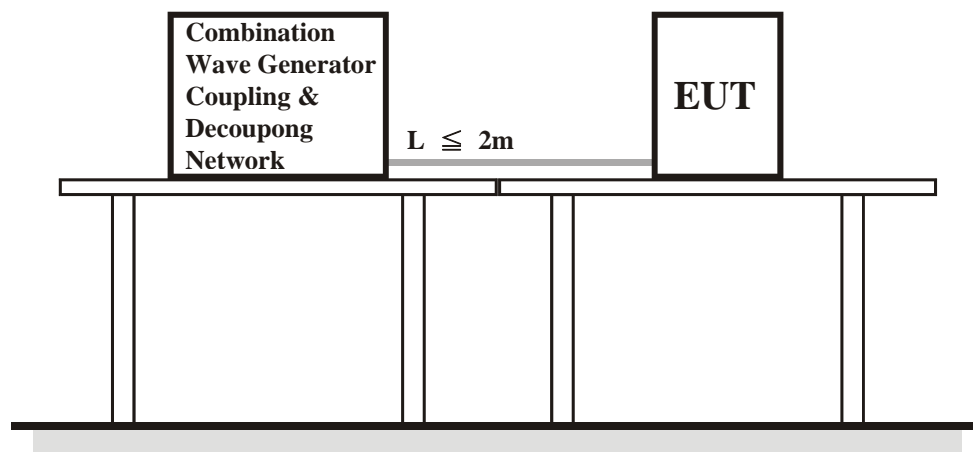

For the actual test configuration, please refer to the related item – Photographs of the Test Configuration.

### 11.4 Test Results

Input Power	230 Vac, 50 Hz	Tested by	Chiming Li
Environmental Conditions	23 °C, 69% RH	Test mode	Mode 1

Auxiliary a.c. power input ports (rated voltage  $\leq 400$  Vrms)

Voltage (kV)	Test Point	Polarity (+/-)	Observation	Performance Criterion
0.5, 1 (42 $\Omega$ + 0,5 $\mu$ F)	L1-L2	+/-	Note	A
0.5, 1, 2 (42 $\Omega$ + 0,5 $\mu$ F)	L1-PE	+/-	Note	A
0.5, 1, 2 (42 $\Omega$ + 0,5 $\mu$ F)	L2-PE	+/-	Note	A

Note: The EUT function was correct during the test.

## 12 Immunity to Conducted Disturbances Induced by RF Fields (CS)

### 12.1 Test Specification

Basic Standard:	EN 61000-4-6
Frequency Range:	0.15 MHz - 80 MHz
Voltage Level:	Battery referenced ports (except at the output of energy sources), Auxiliary a.c. power input ports (rated voltage $\leq$ 400 Vrms), Signal & communication, process measurement & control ports: 10 V
Modulation:	1kHz Sine Wave, 80%, AM Modulation
Frequency Step:	1 % of preceding frequency value
Dwell Time	3 seconds

### 12.2 Test Instruments

Description & Manufacturer	Model No.	Serial No.	Cal. Date	Cal. Due
ROHDE & SCHWARZ Signal Generator	SML03	101801	Jan. 14, 2019	Jan. 13, 2020
Digital Sweep Function Generator	8120	984801	NA	NA
AR Power Amplifier	75A250AM1	306331	NA	NA
FCC Coupling Decoupling Network	FCC-801-M2-16A	01047	Jun. 20, 2018	Jun. 19, 2019
FISCHER CUSTOM COMMUNICATIONS EM Injection Clamp	F-203I-23mm	455	NA	NA
FISCHER CUSTOM COMMUNICATIONS Current Injection Clamp	F-120-9A	361	Jul. 24, 2018	Jul. 23, 2019
B&K Ear Simulator	4185	2553594	NA	NA
EM TEST Coupling Decoupling Network	CDN M1/32A	306508	Jun. 20, 2018	Jun. 19, 2019
TESEQ Coupling Decoupling Network	CDN T800	34428	Jun. 20, 2018	Jun. 19, 2019
TESEQ Coupling Decoupling Network	CDN T800	29459	Jun. 20, 2018	Jun. 19, 2019
FCC Coupling Decoupling Network	FCC-801-T4	02031	Jun. 20, 2018	Jun. 19, 2019
EM TEST Coupling Decoupling Network	CDN T2	306509	Jun. 20, 2018	Jun. 19, 2019
R&S Power Sensor	NRV-Z5	837878/039	Nov. 10, 2018	Nov. 9, 2019
R&S Power Meter	NRVD	837794/040	Nov. 10, 2018	Nov. 9, 2019
TESEQ Coupling Decoupling Network	CDN M232	37702	Jun. 20, 2018	Jun. 19, 2019
TESEQ Coupling Decoupling Network	CDN M332	41258	Jun. 20, 2018	Jun. 19, 2019
TESEQ Coupling Decoupling Network	CDN M332	41256	Jun. 20, 2018	Jun. 19, 2019
TESEQ Coupling Decoupling Network	CDN T400A	28569	Jun. 20, 2018	Jun. 19, 2019
TESEQ Coupling Decoupling Network	CDN T8-10	40376	Jun. 20, 2018	Jun. 19, 2019
TESEQ Coupling Decoupling Network	ISN ST08	41212	Jun. 20, 2018	Jun. 19, 2019
FCC Coupling Decoupling Network	FCC-801-M5-50A	100018	Jan. 21, 2019	Jan. 20, 2020
Software	CS_V7.4.2	NA	NA	NA

- Note:
1. The calibration interval of the above test instruments is 12 months and the calibrations are traceable to NML/ROC and NIST/USA.
  2. The test was performed in CS Room No. 1.
  3. Tested Date: Apr. 16, 2019

### 12.3 Test Arrangement

- The EUT shall be tested within its intended operating and climatic conditions.
- An artificial hand was placed on the hand-held accessory and connected to the ground reference plane.
- One of the CDNs not used for injection was terminated with 50 ohm, providing only one return path. All other CDNs were coupled as decoupling networks.
- The frequency range is swept from 150 kHz to 80 MHz, using the signal level established during the setting process and with a disturbance signal of 80 % amplitude. The signal is modulated with a 1 kHz sine wave, pausing to adjust the RF signal level or the switch coupling devices as necessary. Where the frequency is swept incrementally, the step size shall not exceed 1 % of the preceding frequency value.
- Attempts should be made to fully exercise the EUT during testing, and to fully interrogate all exercise modes selected for susceptibility.

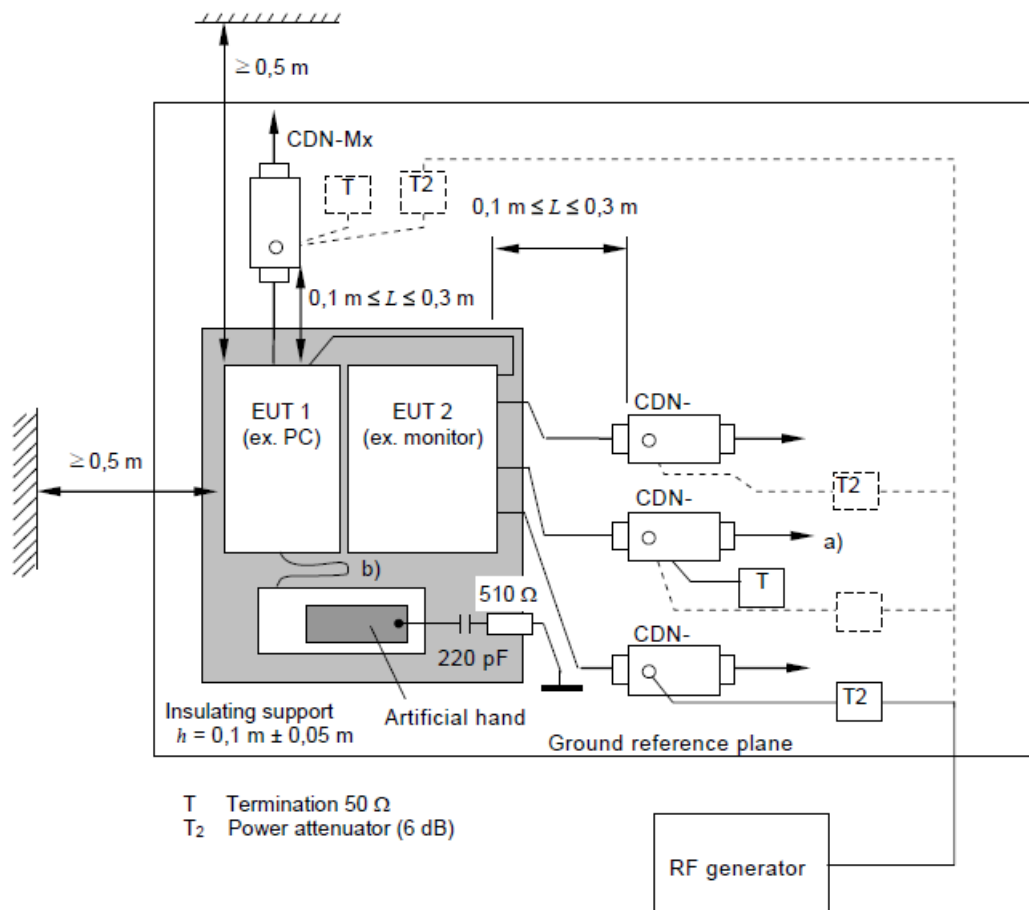

- Note:**
- The EUT clearance from any metallic obstacles shall be at least 0,5 m.
  - Interconnecting cables ( $\leq 1 \text{ m}$ ) belonging to the EUT shall remain on the insulating support.
  - The equipment to be tested is placed on an insulating support of 0.1 meters height above a ground reference plane. All relevant cables shall be provided with the appropriate coupling and decoupling devices at a distance between 0.1 meters and 0.3 meters from the projected geometry of the EUT on the ground reference plane.

For the actual test configuration, please refer to the related item – Photographs of the Test Configuration.

#### 12.4 Test Results

Input Power	230 Vac, 50 Hz	Tested by	Chiming Li
Environmental Conditions	23 °C, 67% RH	Test mode	Mode 1

Frequency (MHz)	Level (V rms)	Tested Line	Injection Method	Return Path	Observation	Remark	Performance Criterion
0.15 – 80	10	AC Power	CDN-M3	ISN ST-08	Note	-	A
0.15 – 80	10	STP LAN	ISN ST-08	CDN-M3	Note	-	A

Note: The EUT function was correct during the test.

## 13 Pictures of Test Arrangements

### 13.1 Conducted Disturbance at Auxiliary a.c. or d.c. power ports





## 13.2 Radiated Disturbance up to 1 GHz

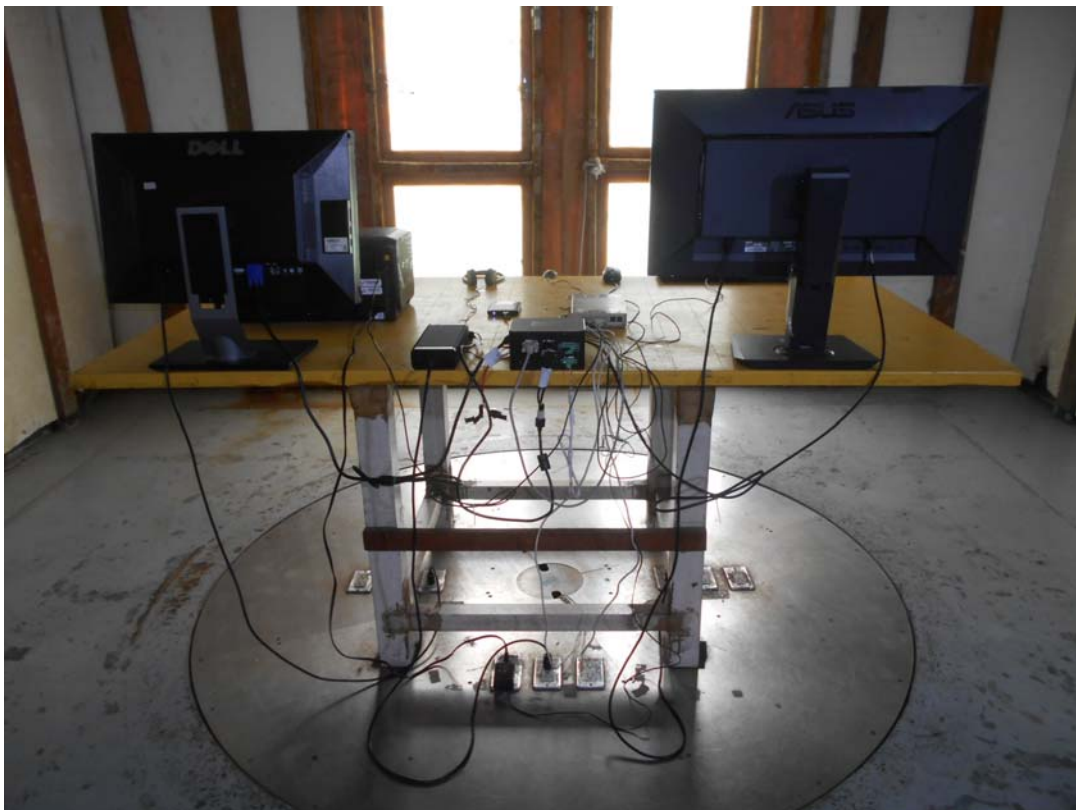

### 13.3 Radiated Disturbance above 1 GHz

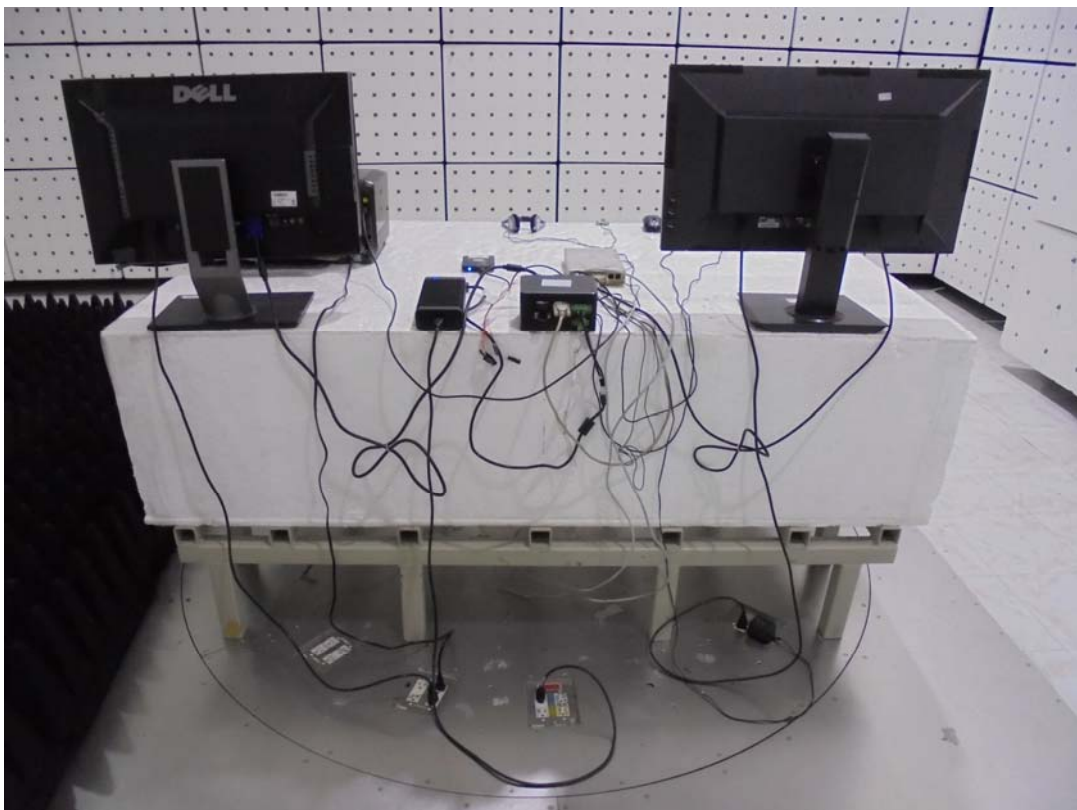



#### 13.4 Electrostatic Discharge Immunity Test (ESD)



### 13.5 Radio-frequency Electromagnetic Field Immunity Test (RS)



### 13.6 Fast Transients (EFT)

Mains ports

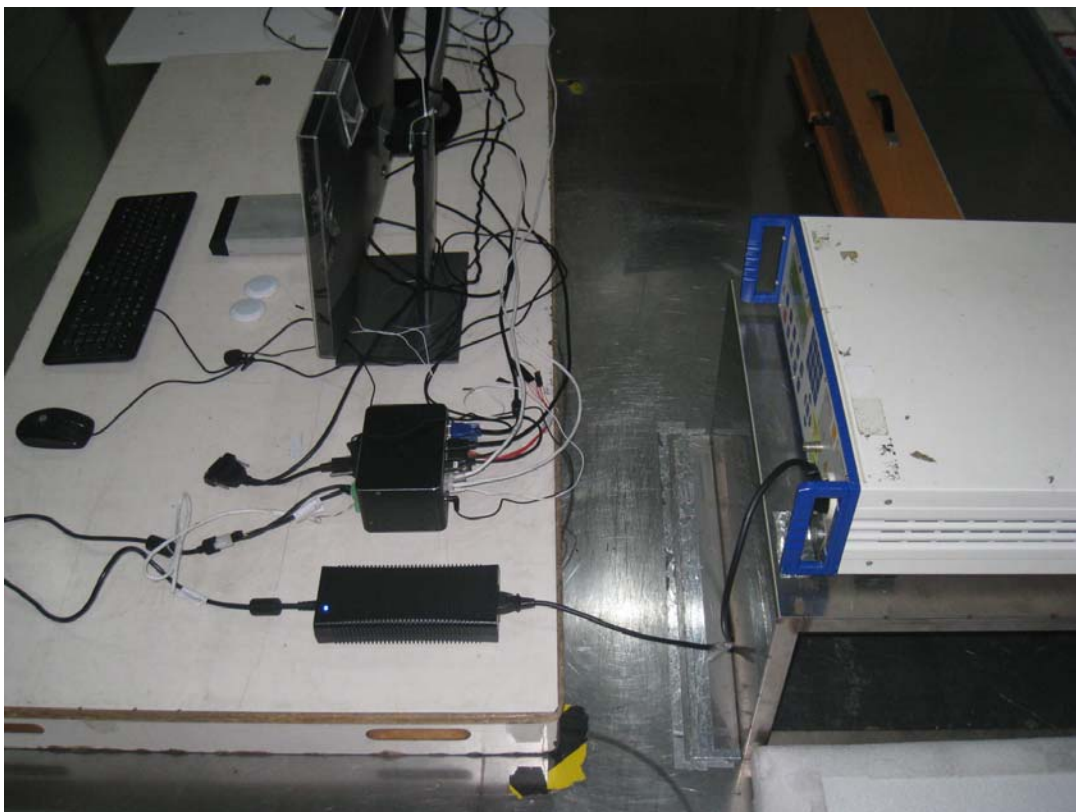

LAN





### 13.7 Surge

Mains ports



### 13.8 Radio-frequency common mode (CS)

Mains ports



STP LAN

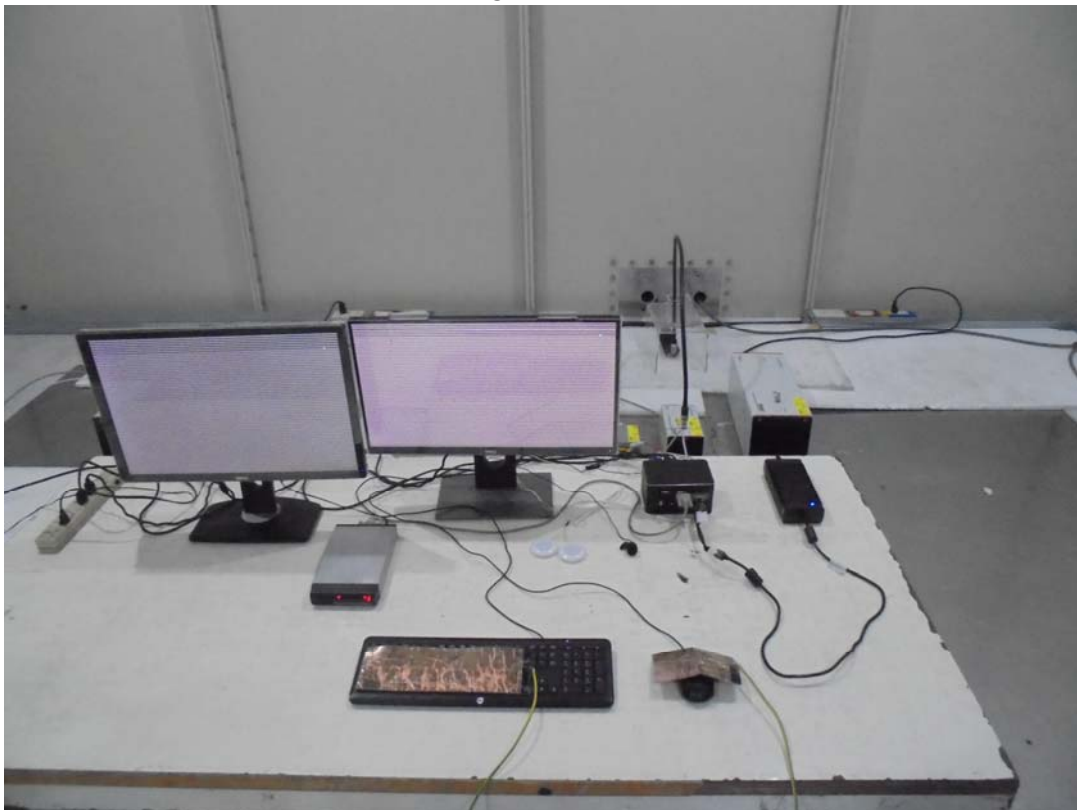

## Appendix – Information of the Testing Laboratories

We, Bureau Veritas Consumer Products Services (H.K.) Ltd., Taoyuan Branch, were founded in 1988 to provide our best service in EMC, Radio, Telecom and Safety consultation. Our laboratories are accredited and approved according to ISO/IEC 17025.

If you have any comments, please feel free to contact us at the following:

**Lin Kou EMC/RF Lab**

Tel: 886-2-26052180

Fax: 886-2-26051924

**Hsin Chu EMC/RF/Telecom Lab**

Tel: 886-3-6668565

Fax: 886-3-6668323

**Hwa Ya EMC/RF/Safety Lab**

Tel: 886-3-3183232

Fax: 886-3-3270892

**Email:** [service.adt@tw.bureauveritas.com](mailto:service.adt@tw.bureauveritas.com)

**Web Site:** [www.bureauveritas-adt.com](http://www.bureauveritas-adt.com)

The address and road map of all our labs can be found in our web site also.

--- END ---